

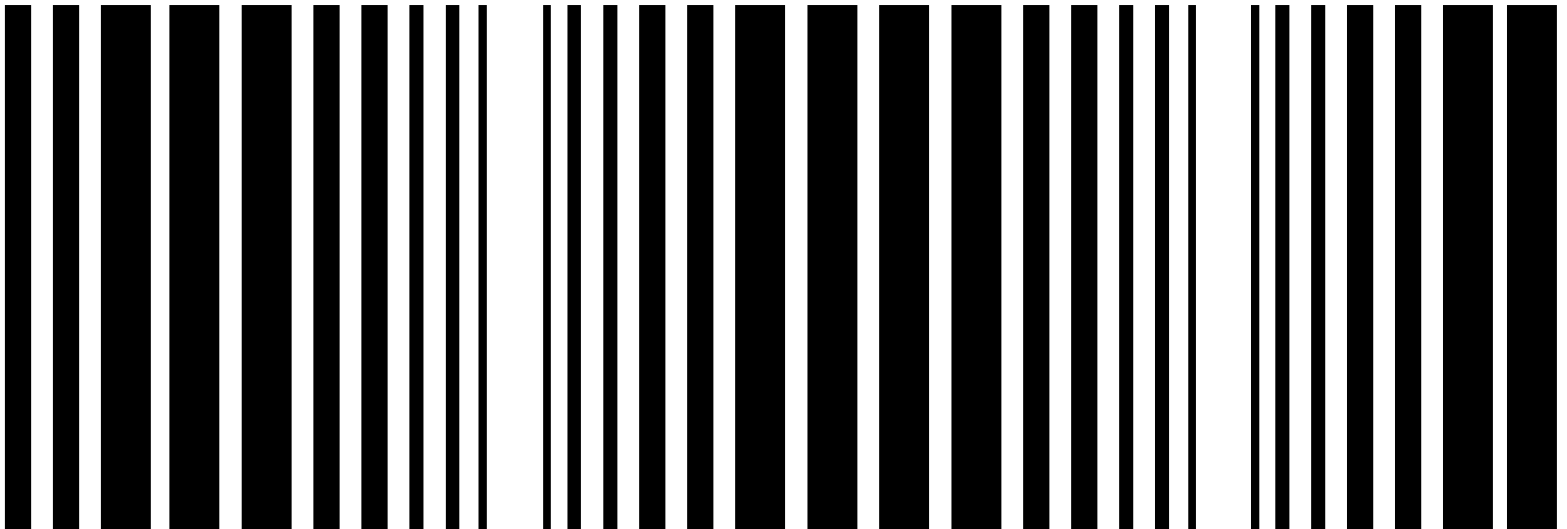

# **Preliminary Industry Characterization: Fabric Printing, Coating, and Dyeing**



## Table of Contents

<u>Section</u>	<u>Page</u>
I. EXECUTIVE SUMMARY .....	I-1
II. FABRIC PRINTING, COATING, AND DYEING .....	II-1
II.1 Introduction .....	II-1
II.2 Summary of Existing Federal Requirements/State Requirements .....	II-2
II.2.1 Federal Regulations .....	II-2
II.2.1.1 Applicability of the NSPS .....	II-2
II.2.1.2 Performance/Control Requirements of the NSPS .....	II-3
II.2.1.3 Applicability of the CTG .....	II-3
II.2.1.4 Performance/Control Requirements of the CTG .....	II-4
II.2.2 State Regulations .....	II-4
II.3 Industry Profile .....	II-8
II.3.1 Basic Textile Manufacturing .....	II-8
II.3.1.1 Carpets and Rugs .....	II-8
II.3.1.2 Polymeric Coating of Substrates .....	II-12
II.4 Applicability .....	II-12
II.5 Process Descriptions and Current Industry Practices .....	II-15
II.5.1 Basic Textile Manufacture .....	II-17
II.5.1.1 Dry Processing .....	II-17
II.5.1.2 Wet Processing .....	II-30
II.5.1.3 Other Operations .....	II-58
II.6 References .....	II-59
APPENDIX A - PARTICIPANTS IN FABRIC PRINTING, COATING, AND DYEING STAKEHOLDER PROCESS .....	A-1
APPENDIX B - DEFINITIONS .....	B-1

## List of Tables

<u>Number</u>		<u>Page</u>
II.2-1	Summary of State Regulations for Fabric Coating . . . . .	II-4
II.3-1	Textile Product - End Uses . . . . .	II-9
II.3-2	Summary of Industry Sectors Constituting Textile Mill Products . . . . .	II-10
II.3-3	Number of Plants that Apply Polymeric Coatings to Supporting Substrate by State . . . . .	II-13
II.5-1	Major Dye Classes and Substrate Fibers . . . . .	II-35
II.5-2	Coating Applicator Parameters . . . . .	II-54
II.5-3	HAP Emissions from Facilities with Coating Operations . . . . .	II-55

## List of Figures

<u>Number</u>		<u>Page</u>
II.4-1	Fabric Printing, Coating, and Dyeing Source Category .....	II-14
II.5-1	Basic Textile Processing .....	II-16
II.5-2	Dry Processing Mill .....	II-18
II.5-3	Suessen Carpet Yarn Heat-Setting .....	II-21
II.5-4	Typical Slashing Range .....	II-25
II.5-5	Example Nonwoven Manufacturing Process Flow Diagram .....	II-28
II.5-6	Woven Fabric Finishing Mill .....	II-31
II.5-7	Typical Fabric Preparation Range .....	II-32
II.5-8	Typical Fabric Dyeing and Finishing Ranges .....	II-36
II.5-9	Dye Machines .....	II-38
II.5-10	Example Carpet Dyeing and Finishing Process Flow Diagram .....	II-44
II.5-11	Typical Rotary Screen Printing Range .....	II-46
II.5-12	Typical Polymeric Coating Range .....	II-52

## PRELIMINARY INDUSTRY CHARACTERIZATION: Fabric Printing Coating and Dyeing

### I. EXECUTIVE SUMMARY

Under Section 112(d) of the Clean Air Act (the Act), the U.S. Environmental Protection Agency (EPA) is developing national emission standards for hazardous air pollutants (NESHAP) for the Fabric Printing, Coating, and Dyeing source category. The EPA is required to publish final emission standards for the Fabric, Printing, Coating, and Dyeing source category by November 15, 2000.

The Act requires that the emission standards for new sources be no less stringent than the emission control achieved in practice by the best controlled similar source. For existing sources, the emission control can be less stringent than the emission control for new sources, but it must be no less stringent than the average emission limitation achieved by best performing 12 percent of existing sources (for which the EPA has emissions information). [In categories or subcategories with fewer than 30 sources, emission control for existing sources must be no less stringent than the average emission limitation achieved by the best performing 5 sources.] The NESHAP are commonly known as maximum achievable control technology (MACT) standards.

The MACT standards development for the textile industry began with a Coating Regulations Workshop for representatives of EPA and interested stakeholders in April 1997 and continues as a coordinated effort to promote consistency and joint resolution of issues common across nine coating source categories.<sup>1</sup> The first phase was one in which EPA gathered readily available information about the industry with the help of representatives from the regulated industry, State and local air pollution agencies, small business assistance providers, and environmental groups. The goals of the first phase were to either fully or partially:

- Understand the textile processes with HAP emission potential
- Identify typical emission points and the relative emissions from each
- Identify the range(s) of emission reduction techniques and their effectiveness
- Make an initial determination on the scope of each category
- Determine the relationships and overlaps of the categories
- Locate as many facilities as possible, particularly major sources
- Identify and involve representatives for each industry segment
- Complete informational site visits
- Identify issues and data needs and develop plan for addressing them
- Develop questionnaire(s) for additional data gathering and
- Document results of the first phase of regulatory development for each category.

The industry members that are participating in the stakeholder process are members of the American Textile Manufacturers Institute (ATMI), Carpet and Rug Institute (CRI), Rubber

---

<sup>1</sup> The workshop covered eight categories: fabric printing, coating and dyeing; large appliances; metal can; metal coil; metal furniture; miscellaneous metal parts; plastic parts; and wood building products. The automobile and light duty truck project was started subsequently.

Manufacturers Association (RMA), Northern Textile Association (NTA), National Association of Hosiery Manufacturers (NAHM), INDA (Association of the Nonwoven Fabrics Industry), Ecological and Toxicological Association of Dyes and Organic Pigments (ETAD), American Yarn Spinners Association (AYSA), Chemical Manufacturers Association (CMA) Solvent's Council, Industrial Fabrics Association International (IFAI), and Single Ply Roofing Institute (SPRI). The States that are participating in the process are Alabama, Florida, Georgia, North Carolina, South Carolina, and Virginia. The U.S. EPA is represented by the EPA Office of Air Quality Planning and Standards (EPA/OAQPS), the EPA Office of Prevention, Pesticides, and Toxic Substances (EPA/OPPTS), the EPA Office of Enforcement and Compliance Assurance (EPA/OECA) and the EPA Office of Research and Development (EPA/ORD). Appendix A contains a list of participants.

The information summarized in this document can be used by States that may have to make case-by-case MACT determinations under Sections 112(g) or 112(j) of the Act. The initial phase of the regulatory development focused primarily on basic textile manufacturing, carpet and rug manufacturing, and fabric coating. This document represents the conclusion of that phase of rule development.

This document includes a description of the emission control technologies the EPA identified that are currently used in practice by the industry and that could serve as the basis of MACT. Within the short time-frame intended for this initial phase, however, only limited data were collected. The information summarized in this document was collected prior to July 15, 1998. Additional information will be collected and considered before the Fabric Printing, Coating, and Dyeing MACT standards are promulgated.

During the next phase, the EPA will continue to build on the knowledge gained to date and proceed with more focused investigation and data analyses. We will also continue our efforts to coordinate cross-cutting issues. We will continue to identify technical and policy issues that need to be addressed in the rule making and enlist the help of the stakeholders in resolving those issues.

Questions or comments on this document should be directed to Mr. Paul Almodóvar (EPA/OAQPS) at 919-541-0283 or at [almodovar.paul@epamail.epa.gov](mailto:almodovar.paul@epamail.epa.gov).

## **II. FABRIC PRINTING, COATING, AND DYEING**

### **II.1 INTRODUCTION**

This chapter presents a summary of existing Federal requirements/State requirements, an industry profile of the textile industry; a description of the likely applicability of the NESHAP for Fabric Printing, Coating, and Dyeing operations; and process descriptions and industry practices including, where applicable, summaries of HAP emissions information and control options. Appendix B contains definitions of some of the important elements and operations that make up the Fabric Printing, Coating, and Dyeing source category for the purposes of this document.

## II.2 SUMMARY OF EXISTING FEDERAL REQUIREMENTS/STATE REQUIREMENTS

### II.2.1 Federal Regulations

Federal volatile organic compound (VOC) regulations that apply to the textile industry include a New Source Performance Standard (NSPS) under 40 CFR Part 60, Subpart VVV, "Standards of Performance for Polymeric Coating of Supporting Substrates Facilities." In addition to the NSPS, the EPA published a Control Techniques Guideline (CTG) document<sup>2</sup> that covers fabric coating operations. The following sections summarize the applicability and the control/performance requirements of the NSPS and the CTG.

#### II.2.1.1 Applicability of the NSPS

The NSPS covers polymeric coating of supporting substrates. The Federal Register notice for the rule (54 F.R. 37540 [1989]) notes that leather-like materials like urethane-coated and bonded leather fiber products are included in the coverage of the regulation. The coating of discrete hides, the graphics arts, and the paper coating industries are not intended to be covered. Commenters to the rule requested a separate subcategory for textile coating operations, but EPA responded instead by lowering the overall required level of control to one they believed all polymer coating lines, including textiles, could meet.

The NSPS covers web coating applying an elastomer or other polymeric material onto a supporting substrate. Specific substrates identified in the Federal Register notice include knit, woven, and non-woven textiles, fiberglass, yarn, and cord. The polymeric coatings mentioned are natural and synthetic rubber, urethane, polyvinyl chloride, acrylic, epoxy, silicone, phenolic and nitrocellulose. (54 F.R. 37534 [1989]).

The rule applies to coating operations that coat a continuous web, defined as the coating applicators, the part of the operation between coating applicator and the drying oven (flashoff areas), and drying ovens. The boundaries of the coating operation are identified as the substrate unwind station and the rewind station. If there is no rewind station, the end of the coating operation is the last drying oven in the process (40 C.F.R. §60.741(a)).

The rule also applies also to onsite coating mix preparation equipment used to prepare coatings for the coating process, i.e., mixing vessels in which solvents and other materials are blended. (40 C.F.R. §60.740(a) and (40 C.F.R. §60.741(a)).

The rule specifically excludes web coating operations that print images on substrate surface or any coating applied on the same printing line that applies the image (40 C.F.R. §60.740(d)(3)).

---

<sup>2</sup> U.S. EPA, Control of Volatile Organic Emissions from Existing Stationary Sources-- Volume II: Surface Coating of Cans, Coils, Paper, Fabrics, Automobiles and Light-Duty Trucks, EPA 450/2-77-008, May, 1977.



### **II.2.1.2 Performance/Control Requirements of the NSPS**

The owner or operator of an affected facility may either reduce VOC emissions from the coating operation by at least 90% or install, operate, and maintain a total enclosure around the coating operation that vents to an add-on control device that is at least 95% efficient. For mix equipment, the standard requires covers and venting to a 95% efficient add-on control device while coating preparation is taking place.

The requirements of Subpart VVV do not apply to coating mix preparation equipment or coating operations during those times they are used to prepare or apply waterborne coating so long as the VOC content of the coating does not exceed 9 percent of the weight of the volatile fraction.

### **II.2.1.3 Applicability of the CTG**

The CTG applies to "fabric coating" which includes all types of coating applied to fabric and to "vinyl coating" which refers to any printing or decorative or protective topcoat applied over vinyl coated fabric or vinyl sheets. It does not include the application of vinyl plastisol to the fabric (emissions from the application of plastisol are near zero). The document specifically identifies the following applications for coated textiles:

- industrial and electrical tapes
- tire cord
- utility meter seals
- imitation leathers
- tarpaulins
- shoe material
- upholstery fabrics

Types of coatings include latex, acrylics, PVC, polyurethanes, and natural/synthetic rubbers.

The specific sources of emissions associated with coating textile substrates are identified as being primarily the coating line (application and drying phases) and fugitive emissions of solvents. Specific points of fugitive emissions are:

- transfer from rail car/tank truck to storage tanks then to processing;
- loss from storage tank vents;
- agitation of mixing tanks vented to the atmosphere;
- solvent evaporation from clean up of coating applicator when color is changed;
- solvent soaked cleaning rags;
- disposal of waste ink sludge with residual solvent (after distillation);
- losses from coatings storage drums as coating pumped to applicator;
- cleaning empty drums with solvent;
- cleaning coating lines with solvent;
- evaporation of solvent from coated fabric after leaving the process.

### II.2.1.4 Performance/Control Requirements of the CTG

The recommended VOC limitation for fabric coating is 0.35 kg per liter (2.9 lbs per gal) of coating (minus water, including exempt solvents) and for vinyl coating is 0.45 kg per liter (3.8 lbs per gal). The limitations are based on the use of an add-on control device which recovers or destroys 81 percent of the VOC introduced in the coating (90 percent capture and 90 percent destruction or recovery). The CTG document also describes the following control techniques for fugitive emissions:

- covers for tanks
- collection hoods for areas where solvent used for clean up
- closed containers for solvent wiping clothes.

### II.2.2 State Regulations

The emission reduction requirements imposed by states and local governments on textile coating operations have been codified by many state legislatures into laws and implemented into regulations. Many of these regulations are based on the CTG reduction requirements, but there is variability as to the specific percent reductions required. There are no specific requirements for other textile operations, though limits may have been placed on emissions of toxic air pollutants from specific facilities through state air toxics regulations.

Table II.2-1 summarizes state and local requirements that impact fabric coating.

**Table II.2- 1 Summary of State Regulations for Fabric Coating**

State/Locality	Operations Covered	VOC Numerical Limit (minus water, including exempt solvents)	Alternate Limit/Compliance Option
Alabama	Printing on Vinyl Coated fabric or printing on vinyl sheets	0.45 kg/l (3.8 lb/gal)	
Alabama	Fabric Coating	0.35 kg/l (2.9 lb/gal)	
California	Fabric Coating		
Bay Area	Fabric Coating	0.26 kg/l (2.2 lb/gal)	0.12 kg/l (1 lb/gal) with a control device

Table II.2-1 (Continued)

State/Locality	Operations Covered	VOC Numerical Limit (minus water, including exempt solvents)	Alternate Limit/Compliance Option
Bay Area, ctd.	Fabric Coating	Rule prohibits liquid leaks from storage/mixing containers & requires lids to be closed except when material is being added or removed, when the tank or container is being cleaned	Cleanup solvents and solvent-soaked cleanup rags required to be kept in closed containers
San Joaquin	Fabric Coating	0.26kg/l (2.2 lb/gal) (including any wash primer used)	OR use a 90% efficient collection system & a 95% efficient control device
San Joaquin, ctd.	Fabric and Paper Coating	Coatings must be applied using one of the following: Flow Coater; Roll Coater; Dip Coater; Foam Coater; Die Coater; Hand Application Methods; High-Volume Low Pressure (HVLP) Spray, for air dried coatings only.	<b>Evaporative loss minimization:</b> Containers & mixing tanks must be leak-free & covered; cleanup material has < 200g/l (1.7 lb/gal) or < 45mm (1.8 in) HG vapor pressure or cleanup area totally enclosed; cleaning/surface prep material & cleanup rags stored in closed containers
San Diego	Paper, Film and Fabric Coating	The coating contains less than 0.26 kg/l (2.2 lb/gal) as applied OR must have combined collection and abatement efficiency of at least 90% on a mass basis at all times during the operation.	Containers & tanks must be free from liquid leaks and must be covered.

Table II.2-1 (Continued)

State/Locality	Operations Covered	VOC Numerical Limit (minus water, including exempt solvents)	Alternate Limit/Compliance Option
San Diego, ctd.		Sale of the following prohibited: any coating or cleaning material that was newly formulated to contain or reformulated to increase the content of methylene chloride, (CFC-11), (CFC-12), (CFC-113), (CFC-114) or (CFC-115). Content of these materials must be shown on label	Cleaning material requirements: must contain < 0.20 kg/l (1.7 lb/gal) OR parts to be cleaned must be totally enclosed during washing, rinsing, and draining processes; OR Cleaning solvent must be transferred through application equipment without exposure to air into a vessel with a tight cover
Georgia	Fabric Coating	0.35 kg/l (2.9 lb/gal)	BUT If any coating delivered to the coating applicator contains more than 0.35 kg/l (2.9 lb/gal), the solids equivalent limit shall be 0.57 kg/l (4.79 lb/gal) of coating solids delivered to the coating applicator.
Illinois	Fabric Coating	0.28 kg/l (2.3 lb/gal) [after 3/15/96]	
Massachusetts	Fabric Coating	0.58 kg/l (4.8lb/gal)	
North Carolina	Fabric Coating	0.48 kg/l (4.0 lb/gal)	0.31 kg/l (2.6 lb/gal) if air pollution control equipment is installed
New Jersey	Fabric Coating	0.35 kg/l (2.9 lb/gal)	
New York	Fabric Coating	0.35 kg/l (2.9 lb/gal)	
South Carolina	Fabric or paper coating	0.35 kg/l (2.9 lb/gal)	specifies ways to meet this limit: 1) low solvent technology; 2) incineration with 90% destruction; 3) carbon bed solvent recovery; 4) others approved case by case.

**Table II.2-1 (Continued)**

<b>State/Locality</b>	<b>Operations Covered</b>	<b>VOC Numerical Limit (minus water, including exempt solvents)</b>	<b>Alternate Limit/Compliance Option</b>
Tennessee	Applies to coating lines but NOT fabric printing lines	0.35 kg/l (2.9 lb/gal)	alternative standard: Installation of capture and control device with 95% destruction OR alternative calculation measures prescribed by regulation
Virginia	Paper and fabric	0.35 kg/l (2.9 lb/gal)	

## **II.3 INDUSTRY PROFILE**

The textile industry supplies the largest non-durable consumer product market in the country. There are more than 4,000 companies (many of which are privately owned) with over 5,000 plants making products with many different end-uses, ranging from apparel to air bags to space suits. The textile industry has 2.2 million direct employees (12 percent of the US workforce) with 700,000 of these employed in the primary textiles segment. <sup>1</sup>

### **II.3.1 Basic Textile Manufacturing**

The basic textile manufacturing industry (broadly defined by production activities identified in SIC major group 22 - Textile Mill Products) is a major and highly diverse component of the US economy. The textile mill products group includes facilities engaged in performing any one of the following operations: (1) preparation of fiber and subsequent manufacturing of yarn, threads, braids, twine, and cordage; (2) manufacturing broadwoven fabrics, narrow woven fabrics, knit fabrics, and carpets and rugs from yarn; (3) dyeing and finishing fiber, yarn, fabrics, and knit apparel; (4) coating, waterproofing, or otherwise treating fabrics; (5) the integrated manufacturing of knit apparel and other finished articles from yarn; and (6) the manufacture of felt goods, lace goods, nonwoven fabrics, and miscellaneous textiles. <sup>2</sup> Although there are textile companies in nearly every State, the Carolinas and Georgia together account for nearly half the industry's employment. <sup>3</sup>

The Institute of Textile Technology (ITT) <sup>4</sup> reports that the textile industry consists of complex product mixes and that each facility has unique physical/chemical production processes, machinery, raw materials, and environmental issues. As displayed in Table II.3-1, the industry produces numerous end products. Textile equipment is very flexible and companies often have to make numerous and rapid adjustments to product lines and changes to properties of existing products in response to market conditions. Table II.3-2 describes the major SIC codes that constitute the textile industry and describes some of the products and processes that fall under each.

For the purpose of background information collection, two segments of the basic textile manufacturing industry that have distinct characteristics, use different terminology, or produce distinct end-products, have been identified. These segments are carpets and rugs and polymeric coating of supporting substrates. The following sections provide more detailed industry profiles of these segments.

#### **II.3.1.1 Carpets and Rugs**

Although there was not very much growth in the carpet industry through the 1960's, there have since been dramatic increases in carpet production. Total carpet production in the US currently reaches 1.6 billion square yards annually and represents a retail value of about \$15 billion. <sup>7</sup>

**Table II.3-1. Textile Product - End Uses**

Application	Example products
Apparel	Clothing (woven and knits), hosiery, belts
Defense	Several products, e.g., material for flags, lightweight fibers for aircraft wings, tents, parachutes, bullet-proof vests, helmets.
Space exploration	Textile-based heat shields, space suits
Medical	Artificial arteries and kidneys, bandages
Industrial	Liners for highways and reservoirs, belts, gaskets, hoses, gloves
High-tech uses	Communications satellites (fabrics in panels, circuit boards, receivers and senders), fabric roofs, printed circuit boards in computers and other electronic equipment
Automobiles and airplanes	Tire cord, upholstery, roof liners, hoses
Home furnishings	Carpets, sheets, towels, draperies, upholstery
Others	Firefighter uniforms, dental floss, food packaging, luggage, insulation, and other uses

Source: Reference 5.

**Table II.3-2 Summary of Industry Sectors Constituting Textile Mill Products**

SIC and Title	Description	Concentration
2211 - Broadwoven Fabrics Mills, Cotton	Weaving fabrics more than 12 inches in width, chiefly made from cotton (no carpets, tire cord, or finishing).	Leading States are NC, SC, GA, and AL. Value of shipments: 5.8 billion.
2221, Broadwoven Fabrics Mills, Manmade Fiber and Silk	Weaving fabrics more than 12 inches in width, mainly made of silk and manmade fibers, including glass (no carpets, tire cord, or finishing).	Leading States are SC, NC, GA, and VA. Value of shipments: \$8.8 billion.
2231, Broadwoven Fabrics Mills, Wool	Weaving fabrics more than 12 inches in width, mainly made of wool, mohair, or similar animal fibers, dyeing and finishing of all woven wool fabrics or wool, tops, or yarn (no carpets).	Leading States are VA, GA, Maine, and NC. Value of shipments: \$1.6 billion.
2241, Narrow Fabrics Mills	Weaving or braiding of narrow fabrics (12 inches or less) of cotton, wool, silk, and manmade fibers, including glass. Also fabric covered elastic yarn or thread.	Leading States are NC, PA, RI, and SC. Value of shipments: \$1.3 billion.
2251 - 52, Hosiery*	Hosiery knitting, dyeing, and finishing	Leading State is NC. Value of shipments: \$4.3 billion.
2253 - 59 Knit goods*	Knitting, also dyeing / finishing weft/warp knit fabrics and lace goods.	Leading States vary according to specific segment.
2261, Finishing Plants, Cotton	Finishing broadwoven cotton fabrics - includes chemical / mechanical finishing, and printing. No coating, or finishing of wool or knit goods.	Leading States are NC, SC, and GA. Value of shipments: \$2.6 billion.
2262, Finishing Plants, Manmade	Finishing manmade fiber and silk broadwoven - includes chemical / mechanical finishing, and printing. No coating, or finishing of wool or knit goods.	Leading States are NC, SC, and NJ. Value of shipments: \$3.4 billion.
2269, Finishing Plants, N.E.C.	Dyeing and finishing, not elsewhere classified. Examples include bleaching, dyeing, and finishing of raw stock, yarn, braided goods, and narrow fabrics (no wool and knits).	Leading State is NC. Value of shipments: \$1.1 billion.
2273, Carpets and Rugs	Manufacturing woven, tufted, and other carpets and rugs from textiles or other materials such as twisted paper, grasses, jute, etc.	Leading State is GA. Value of shipments: \$9.8 billion.



**Table II.3-2 (Continued)**

SIC and Title	Description	Concentration
2281, Yarn Spinning Mills	Spinning yarn made chiefly from cotton, manmade fibers, silk, wool, mohair, or other similar animal fibers. No yarn dyeing or finishing.	Leading States are GA, NC, and SC. Value of shipments: \$7.7 billion.
2282, Throwing and Winding Mills	Texturizing, throwing, twisting, winding, or spooling yarns or manmade fiber filaments - made chiefly of cotton, manmade fibers, silk, wool, mohair, or similar animal fibers. No dyeing or finishing.	Leading State is NC. Value of shipments: \$2.8 billion.
2284, Thread Mills	Manufacturing thread of cotton, silk, manmade fibers, wool, or similar animal fibers. No flax, hemp, etc.	Leading State is NC. Value of shipments: \$837 million.
2295, Coated Fabrics, Not Rubberized	Coated, impregnated, or laminated textiles, and special finishing, such as varnishing or waxing. No dyeing or (regular) finishing.	Leading States are MA and OH. Value of shipments: \$1.5 billion.
2296, Tire Cord and Fabrics	Manufacturing cord and fabrics for use in reenforcing rubber tires, industrial belting, fuel cells, and similar uses.	Leading States are AL and GA. Value of shipments: \$981 million.
2297, Nonwoven Fabrics	Manufacturing nonwoven fabrics by mechanical, thermal, or solvent means (or combinations). No felts.	Leading States are NC and TN. Value of shipments: \$2.9 billion.
2298, Cordage and Twine	Rope, cable, cordage, twine, and related products from abaca, sisal, henequen, hemp, cotton, jute, flax, manmade fibers including glass, and other fibers.	Leading States are AL and NC. Value of shipments: \$672.7 million.
2299, Textile Goods, N.E.C.	Textile goods, not elsewhere classified. Includes linen goods, jute goods, felt goods, padding and upholstery filling, processed waste, and recovered fibers and flock. Fiber preparation (for spinning), including wool carbonizing and scouring - are also covered here.	Leading States are NY, NC, and SC. Value of shipments: \$1.8 billion.
2300, Apparel*	All facilities in major group 23 are engaged in manufacturing different types of apparel goods.	-
2823 or 2834	Facilities primarily engaged in producing and texturizing manmade fiber filaments and yarns in the same plant.	-
3069	Rubberized coatings applied to fabrics.	

\* Not the actual title  
Source: Reference 6.

This growth came with the creation of new manmade fibers as well as modern techniques for tufting and color application. The largest companies are Shaw Industries, Mohawk Industries, Beaulieu Carpets, and Queen Carpets. Until the 1980's, most carpet producers relied on chemical fiber companies such as DuPont and Monsanto or independent yarn spinners, to extrude their fiber. However, today carpet mills produce over 80% of the spun yarns they need and extrude about 35% of the industry's face fiber requirements. There are currently 255 carpet mills in 23 States (9), but over 74% of all carpet (177 mills) in the US is manufactured in Georgia, with the remainder manufactured in California and other States. <sup>8</sup> It is estimated that 25 companies in the industry produce 94% of the nation's carpets and rugs; and the top 10 produce 75%. <sup>9</sup>

Major carpet markets include residential, commercial, residential contract, transport, and outdoor (e.g, sports arenas). Close to 90% of the market is concentrated in the residential, residential contract, and commercial applications. The types of fibers and techniques used depend heavily on end-uses. For example, low soiling and easy cleaning nylon fibers dominate in the commercial market. The most important face fibers used in the carpet industry, in terms of market share, include nylon (62.3%), polypropylene (31.5%), polyester (5.8%), and wool (0.42%). <sup>10</sup> Fibers such as cotton and acrylic are not used in significant quantities. Since polypropylene is the easiest fiber to extrude, it has been the fiber of choice for carpet companies that do their own extrusion, although some companies have started extruding nylon as well. <sup>11</sup>

### **II.3.1.2 Polymeric Coating of Substrates <sup>12</sup>**

Polymeric coating is a subcategory of web coating that encompasses coating of several types of substrates, including not only fabrics, but also flexible substrates such as paper and metal coil, which are other source categories for which MACT standards are being developed. There are two general categories of coated products. In the first category, the coated substrate takes on a combination of properties from both the coating and the substrate. Examples of this category of coated product include polyester fabric coated with vinyl for use in awnings or polyester fabric coated with synthetic rubber for use in flexible hoses. The second general category consists of substrates that are coated with epoxy or phenolic resins, e.g., fiberglass fabric coated with phenolics for use as military fabric.

In 1984, there were at least 128 domestic plants owned by 108 companies that performed polymeric coating. The distribution of plants by State is presented in Table II.3-3. Polymeric coating may be classified into two broad categories, commission and captive (non-commission) coaters. The commission coater has many customers and produces coated substrates according to each customer's specifications. The captive coater produces coated substrate as an intermediate product in a manufacturing process.

## **II.4 APPLICABILITY**

The NESHAP for Fabric Printing, Coating, and Dyeing operations would likely apply to all existing, new, or reconstructed facilities that are a major source of HAP emissions as defined in the 1990 Clean Air Act Amendments with textile processes that emit HAP material. Figure II.4-1 is a diagram of the Fabric Printing, Coating, and Dyeing source category showing textile processes that are known to emit HAPs and potentially could be covered by the MACT standard. Textile processes

Table II.3-3. Number of Plants that Apply Polymeric Coatings to Supporting Substrate by State

State	No. of Plants
Alabama	1
Arkansas	2
California	7
Colorado	1
Connecticut	7
Florida	1
Georgia	6
Illinois	3
Indiana	2
Kansas	1
Maryland	1
Massachusetts	18
Michigan	2
Minnesota	1
Mississippi	1
Missouri	2
New Hampshire	2
New Jersey	9
New York	10
North Carolina	6
Ohio	13
Pennsylvania	2
Rhode Island	7
South Carolina	8
Tennessee	5
Texas	3
Vermont	1
Virginia	3
Wisconsin	3
TOTAL	128

Source: Reference 13

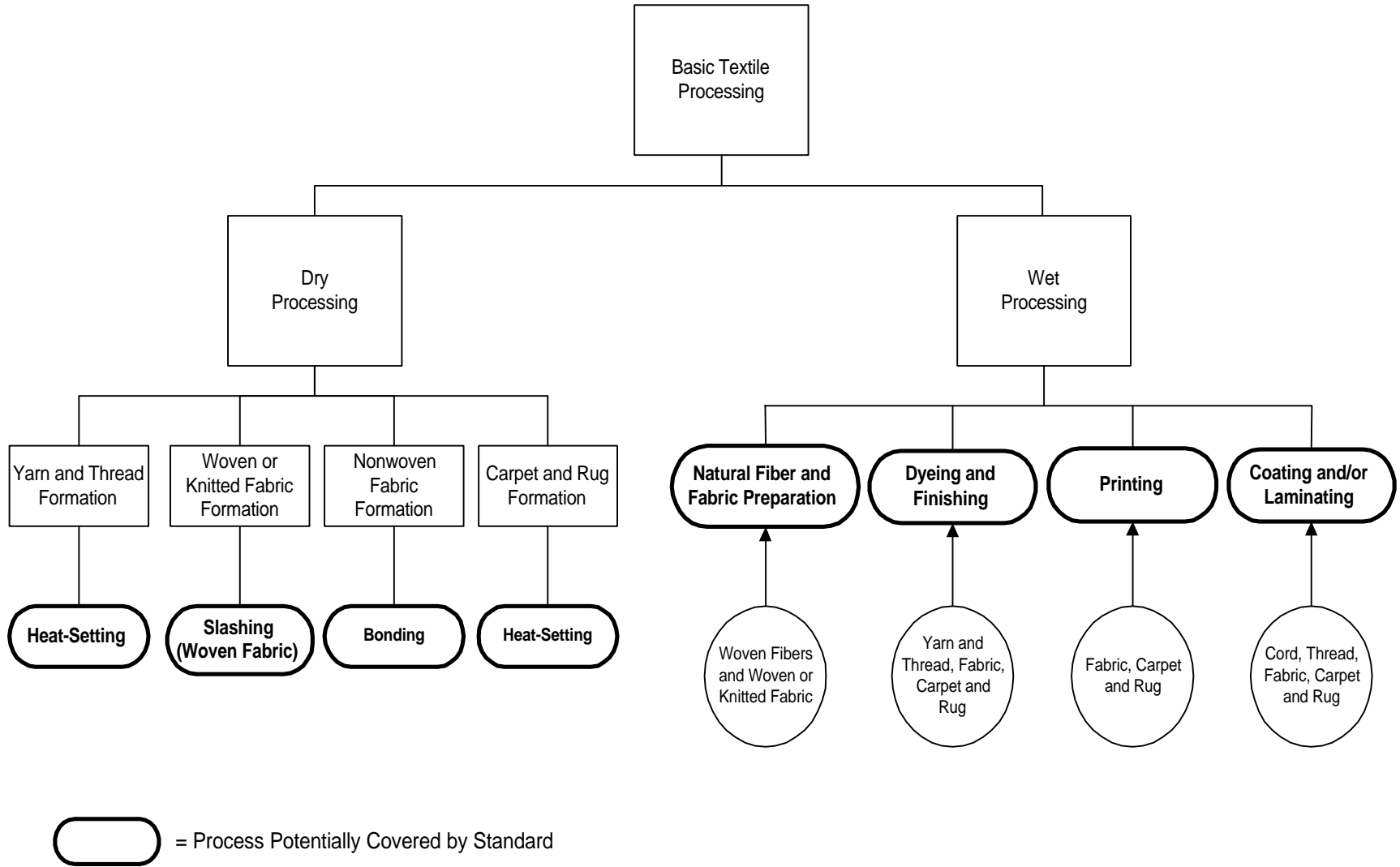

Figure II.4-1. Fabric Printing, Coating, and Dyeing Source Category

that emit HAPs but are subject to the requirements of other MACT standards; and therefore, will not be covered under the Fabric Printing, Coating, and Dyeing source category include flame lamination, tire cord coating, processing of fiberglass textile substrates, and production of nonwoven fabrics for roofing.

The Fabric Printing, Coating, and Dyeing source category has a potential overlap with the Paper and Other Web Coating source category in the production of laminates consisting of fabric and paper and in printing. The development of these standards is being coordinated to ensure consistent requirements covering HAP emissions from the lamination of paper and fabric and from printing.

## **II.5 PROCESS DESCRIPTIONS AND CURRENT INDUSTRY PRACTICES**

The characterization of textile manufacturing is complex because of the wide variety of substrates, processes, components used, and finishing steps undertaken. Different types of fibers or yarns, method of fabric construction, and finishing operations (including preparation, printing, dyeing, chemical/mechanical finishing, and coating), all interrelate in producing a finished fabric. When one of these components is changed, the properties of the end product are affected. There are several properties that can be used to define a fabric and one or more of a fabric's inherent properties may be modified during processing to give it the desired end characteristics. Some examples of fabric properties include weight, appearance, texture, strength, luster, flexibility, and affinity to dyestuff.<sup>14</sup>

Figure II.5-1 is a generalized flow diagram depicting the various textile processes that are involved in converting raw material to finished product. All of these processes do not necessarily occur in a single facility, although there are some integrated mills. There are also several niche areas and specialized products that are developed in the textile industry (see Table II.3-1) which may entail the use of special processing steps that are not shown in Figure II.5-1. In general, most dry process steps, depicted in Figure II.5-1, are not significant sources of HAP emissions.

The textile industry has traditionally focused more on water-related environmental issues and air issues of interest have primarily been related to opacity (condensed hydrocarbons). To that end, most of the air pollution control equipment being used today in the textile industry has been installed solely to reduce visible emissions. However, the industry recognizes that the chemical compositions of their diverse raw materials is an important issue due to its relation to air emissions of hazardous air pollutants (HAPs) and volatile organic compounds (VOCs). The major sources of HAP emissions from textile processes consist of operations that include drying, curing, or heat-setting steps. In general, the types of controls reported to be used in textile facilities to control visible emissions or VOCs include venturi scrubbers, incinerators / afterburners, fabric filters / demisters, and electrostatic precipitators.<sup>16</sup> In stakeholder meetings, industry representatives have stressed that they preferred substitutions / process modifications as a way to control air emissions, as compared with end-of-pipe add-on controls.

The following sections describe the various textile processes involved in the production of textile mill products, including those that do not emit significant HAPs. The process information is taken from textile publications, while an important source of emissions information is the ATMI MACT survey<sup>17</sup> that was conducted in Spring, 1997. Each process description includes information on the

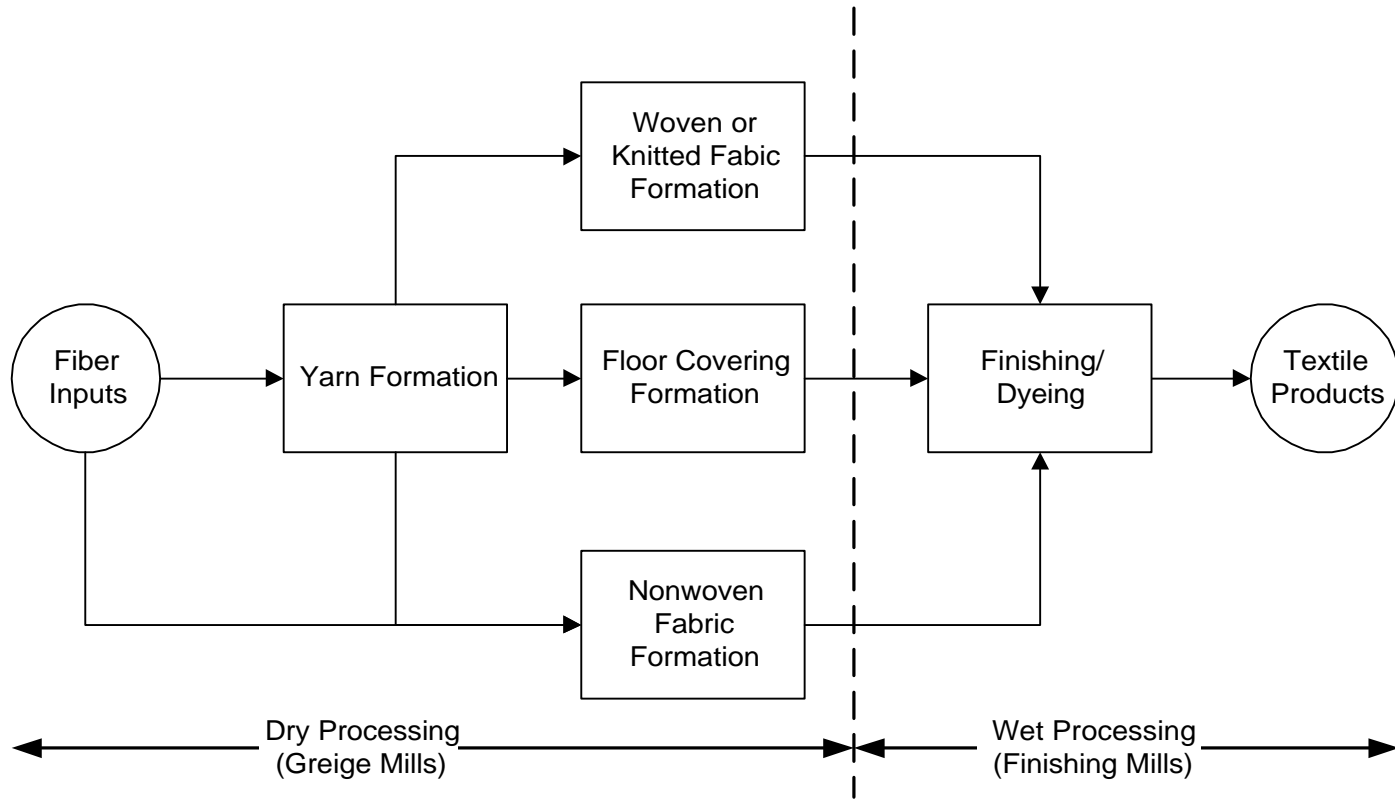

Source: Reference 15

Figure II.5-1. Basic Textile Processing

equipment and chemicals used, sources of HAP emissions, pollution prevention (P2) options, and types of controls currently in use. Carpet manufacturing steps are described separately in these sections, primarily because separate segments of the textile industry carry out these processes. All processes that potentially are HAP emission sources are flagged as such in the section headings.

## **II.5.1 Basic Textile Manufacture**

In basic textile manufacture, raw natural or manufactured (manmade) fibers are processed to manufacture finished fabric. As shown in Figure II.5-1, textile operations can be broadly classified into 'dry' processing and 'wet' processing.<sup>18</sup> It should be noted that 'dry' and 'wet' can be misleading terms since some dry processes like slashing are actually wet and some finishing ('wet') processes are actually dry. Dry processing primarily includes mechanical processes, the majority of which do not have significant HAP emissions, with the exceptions of slashing and nonwoven fabric production. 'Dry' processing includes two main stages of processing; yarn production and fabric production. 'Wet' processing, which includes preparation, dyeing, and finishing, is a combination of chemical and mechanical processes, has various potential sources of HAP emissions. 'Wet' processing includes two main stages of processing; fabric preparation and fabric finishing.

### **II.5.1.1 Dry Processing**

Since most dry processing steps are not significant contributors to HAP emissions, they are dealt with only briefly in this chapter. As has been noted before, the only wet processes that fall within the broad stage of dry processing are slashing and nonwoven fabric production (chemical bonding). These processes potentially result in HAP emissions and are described in greater detail. The description of dry processing will include mills involved in yarn manufacture, yarn texturing/heat-setting, and unfinished fabric manufacture.

Figure II.5-2 is a schematic showing typical process steps in a dry processing mill, along with information on potential sources of HAP emissions. The specific nature and sequence of these operations will depend upon the substrates being processed and the desired end product. Two general categories of fiber used in the textile industry include natural (e.g., cotton and wool) and manmade, which includes cellulosic (e.g., rayon and acetate), and synthetic (e.g., polyester and nylon).

The first process operation is to prepare (manmade fibers) or manufacture (natural fibers) the fiber, after which the yarn may be spun. The next few steps depend on the requirements of the end product. If the fabric is to be woven, a protective coating called a size is first applied to warp yarns in a process termed as slashing. It should be noted that yarn or thread may also be dyed before being woven or knitted into fabric. Some fabrics are also manufactured using nonwoven processes, which could have associated HAP emissions. Other ancillary operations include those such as fabric inspection and spot cleaning, which may also be done following finishing. These operations are described in Section II.5.1.3 following all the process descriptions since they are likely to be similar regardless of the stage in which they are performed.

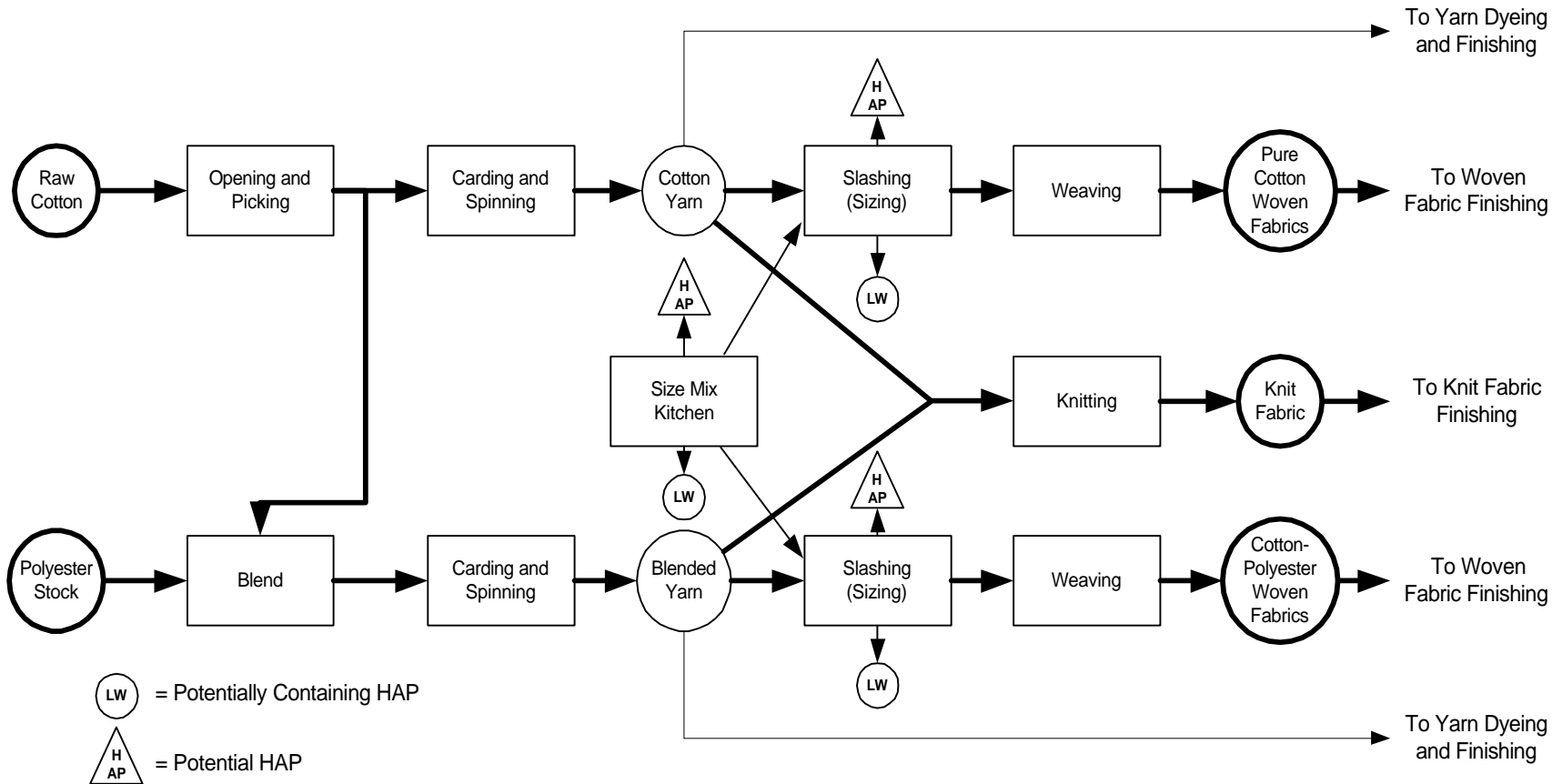

Source: Reference 19

Figure II.5-2. Dry Processing Mill



#### **II.5.1.1.1 Natural Fiber Preparation.**

Natural fibers require several steps to open and clean the fibers to prepare them for yarn manufacturing. The first step, termed as opening and blending, is typically to take the natural fibers from compressed bales and sort and clean them to remove dirt and impurities. The next several steps are aimed at teasing out the fibers, lengthening them, and aligning them into thin parallel sheets, with each successive step resulting in a finer product. These steps are carding, combing, drawing, and drafting; all of which prepare the fiber for spinning. Different types of fibers may be blended (combined) during drawing or following drafting. After drafting, the yarn is wound onto rotating spindles, which are mounted on to spinning frames, where they are set for spinning.<sup>20</sup> These steps will vary according to the fiber being processed and the desired end-product.

In woolen and worsted systems, the fiber lengths range from 2.5 to 9 inches (as opposed to under 2.5 inches in short staple spun yarn) and the yarns have a fuzzier appearance. In processing wool, some type of acid treatment or scouring may be required to remove impurities. Such chemical treatments could be sources of HAP emissions. Other worsted systems may require chemical cleaning as well, which would typically entail use of a soap or alkali, which is further neutralized with an acid before final rinsing.<sup>21</sup>

#### **II.5.1.1.2 Manmade Fiber and Yarn Manufacture.**

Manmade fibers do not need to go through the same cleaning and fiber preparation steps that natural fibers undergo. The manmade fibers can be manufactured by three different methods, each of which involves forcing a liquid through a small opening, where the liquid solidifies to form a continuous filament. These methods are melt spinning, dry spinning, and wet spinning, and each is used to produce different types of manmade fibers. Melt spinning requires no chemical reactions and no solvent recovery system and is typically used to manufacture nylon, polyester, olefin, and glass. Dry spinning is used to produce acrylic, acetate, triacetate, spandex, and aramid. It uses a solvent that evaporates, but is generally recovered for reuse. Wet spinning also makes use of a solvent and is used to produce rayon, acrylic, and modacrylic.<sup>22</sup> Wet spinning requires washing to remove impurities and solvent and chemicals are recovered after use.<sup>23</sup>

Manmade fibers may also be blended with natural fibers (as described in the above section) or may be produced in lengths that make it suitable for processing on wool or cotton-system machinery.<sup>24</sup> Although manmade fiber production could result in HAP emissions, these would be covered under separate source categories.

#### **II.5.1.1.3 Texturing and Heat-Setting (Potential HAP emissions).**

After spinning, the manmade fibers are drawn to align and orient the polymer molecules and strengthen the filament. This may be followed by texturing.<sup>25</sup> Texturing is a process of crimping, importing random loops, or otherwise modifying continuous filament yarn to increase cover, resilience, abrasion resistance, warmth, insulation, or moisture absorption, or to provide a different surface texture.<sup>26</sup> Texturing basically involves deforming the filaments (such as by imparting a twist) with a mechanical process to give manmade fibers spun-like properties, after which the deformation is set, usually by a heat-setting process (the deformation is not always heat-set). Heat-

setting is typically done only for synthetics, does not involve application of any chemicals, and can be done on a semi-contact oven or tenter frame. In false-twist texturing, the deformation is further removed.<sup>27</sup>

Heat-setting involves applying high temperatures (350 - 400°F) to confer dimensional stability to the synthetic fabrics, or blends (e.g., poly-cotton) containing thermoplastic fibers. One function of heat-setting is to prevent creasing during processing.<sup>28</sup> No chemicals are applied; however, the high temperature required for heat-setting will volatilize spin finishes that may have been applied to the fibers, some of which may contain HAPs. Fiber is heated in a semi-contact oven or tenter frame under tension above its glass transition temperature and held for a period of time.<sup>29</sup> It is typically used on polyester, nylon, and triacetate, and not on rayon, cotton, and acrylics.<sup>30</sup>

Heat-setting is also used for stabilization of carpet yarns by exposure to heat, prior to the tufting process, or prior to binder or resin application in nonwoven carpet manufacture. Not all yarn is heat set (just cut pile). The principal benefits of heat-setting are twist retention in plied yarns in cut pile carpet and general stabilization of yarn configuration. There are 3 heat-setting methods for carpets, classified by type of equipment used; Superba, autoclave, and Suessen (see Figure II.5-3).

Superba and Suessen systems are continuous operations and the autoclave method is a batch process that is no longer common. In batch process heat-setting in conventional autoclaves, yarns are first treated in a tumbler containing circulated live steam at around 140°F for around 5 minutes. Skeins can weigh from 7 to 10 pounds with a circumference of approximately 96 inches. The skeins are then loaded onto a metal basket and rolled into an autoclave, a large pressure vessel automatically programmed for a desired heat and twist setting cycle (temperatures ranging from 240 - 300°F).<sup>31,32</sup>

In both Suessen and Superba systems, yarn to yarn strands are twisted into one strand prior to the operation. Superba machines consist of two units, each of which can process 6 to 24 continuous yarn ends. Yarn feed rates are about 1230 feet per minute. Twisted yarn is loosely coiled into a perforated plastic or stainless steel conveyor belt which passes through an enclosed low pressure steam bath, a prebulker, which bulks the yarn prior to its passage through the Superba. Temperatures in the central zone of the Superba are about 260-280°F with pressures of approximately 55 psi. Dwell time ranges from one to two minutes, and no steam is introduced in the core chamber (dry heat). After being heat-set the yarn is cooled and wound.<sup>33</sup>

Suessen systems consist of six heat-set tunnels each of which averages a yarn feed rate of 2100 to 2800 feet per minute. Air operated injectors guide yarn ends from twister bobbins to one of six rope conveyors. The yarn is wound around the conveyor ropes which pass through the heat-set chamber, where it can contact dry heat (383°F), saturated steam (212°F), or superheated steam (356°F), depending on preset chamber conditions. Actual heat-setting conditions are usually between 284 - 384°F, with the yarn dwell time ranging from one to two minutes. After heat-setting, yarn is wound onto cones, packaged, and sent to the carpet mill.<sup>34</sup>

Fiber production and yarn processing steps add several chemicals to fibers (tints and finishes) to make the fibers easier to process. Heat-setting in Superba or Suessen systems could cause these chemicals to be released in the form of HAPs or visible emissions. Spin finishes are typically oils or emulsions applied to fibers to give them cohesion and lubricity characteristics. These could

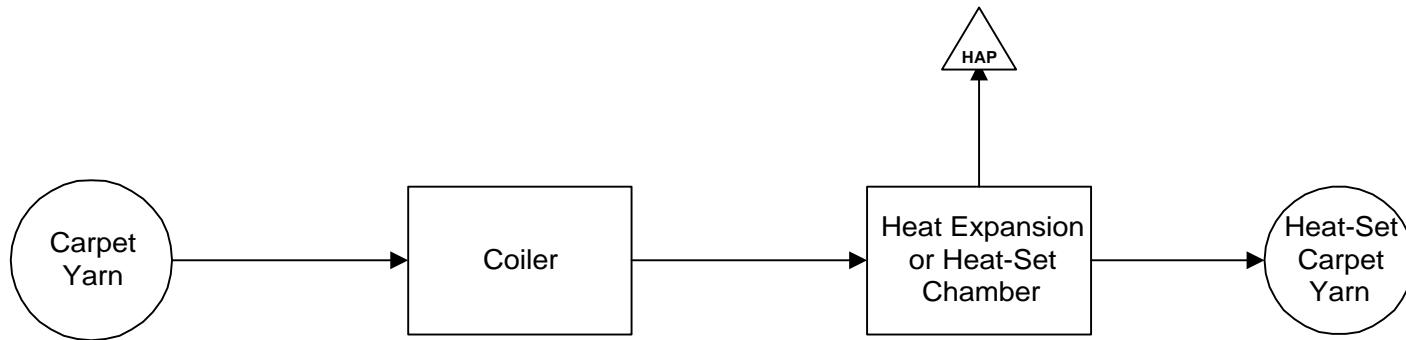

 = Potential HAP Air Emission

Figure II.5-3. Suessen Carpet Yarn Heat-Setting

contain hazardous ingredients, although constituents are often proprietary. For example, EzSpin manufactured by Waco Chemical contains trace quantities of ethylene oxide. Tints are fugitive (i.e., not permanent), biodegradable, colored chemicals mixed with finishes and applied to fiber to aid in fiber identification. Other sources that could have hazardous ingredients include various types of equipment and oven cleaners (residuals may be emitted). Cleaning operations can be daily, weekly, or quarterly. The primary constituents of the fibers themselves could be HAP sources. For example, nylon 6 is formed by polymerizing caprolactam (no longer a HAP), which is emitted during Suessen heat-setting of nylon 6 yarns. Polyester fibers can contain dimethyl terephthalate (not a HAP) and ethylene glycol (a HAP).<sup>35</sup>

**HAP emissions:** Heat-setting operations have the potential to result in or contribute to major HAP emissions.<sup>36</sup> Heat-setting emissions include methanol, formaldehyde, and glycol ethers (greater than 1 TPY) and smaller quantities of other emissions.

In an air emission assessment study conducted at a textile finishing plant,<sup>37</sup> no emissions were estimated by mass balance, given that no chemicals were added at the textile plant. However, stack measurements from the poly/cotton heat-set range included emissions of VOCs, formaldehyde, and glycol ethers and glycols. Only the VOCs were measured at greater than 1 TPY. Source testing was performed on the main stack of 6 Suessen heat-set tunnels and on one autoclave at a carpet fiber processing facility in Georgia.<sup>38</sup> The measured autoclave emissions (including formaldehyde and acetaldehyde) were on the order of magnitude of pounds per year. The Suessen emissions were estimated as 34.7 tons per year of VOC using the highest conversion factor of targeted compounds to convert from pounds of carbon measured to pounds of VOC. Previous studies of VOC emissions from heat-setting carpet fiber have shown the VOC emissions to be approximately 50 percent caprolactam. Speciation of the emissions identified formaldehyde and acetaldehyde; the emissions of these HAPs were not quantified.

According to an initial assessment of emissions from heat-setting carpet yarn,<sup>39</sup> under normal operating conditions, temperature of heat-setting machines is not significant enough to cause fiber degradation. The proprietary nature of many of the chemicals applied to fibers also makes predicting potential HAP emissions difficult. Superba operating conditions are not likely to be substantial enough to cause finish materials to volatilize, or for yarn fibers to degrade. Emissions generated from Superba operations are believed to be steam from prebulk operations.<sup>40</sup> On the other hand, Suessen conditions are substantially different, with temperatures being significantly higher, possibly approaching glass transition temperatures, thus creating the potential for fiber degradation.

**Control Options:** A primary control option is the use of spin finishes that do not contain HAPs. Most facilities are not using any add-on controls for heat-setting, although a small number of facilities use incinerators/afterburners.<sup>41</sup> Emissions from heat-setting carpet yarn are generally uncontrolled. There is some use of condensers or absorbers to control PM and VOC contributing to visible emissions.<sup>42</sup>

#### **II.5.1.1.4 Yarn and Thread Spinning.**

Yarns are classified either as spun yarns or filament yarns. Spun yarns use staple (finite) length natural or manmade fibers combined to produce a yarn with high strength and structural integrity

properties. Spinning may involve additional twisting or texturing (see previous section), or multiple yarns may be twisted together to form plied yarns (may be further plied to make ropes, thicker cords, and cables). Filament yarns are produced from filament fibers in a process known as throwing. Manmade filaments may require additional drawing. Filament yarns are continuous forms in which the length of the fiber is essentially infinite, resulting in the yarn's structural strength and integrity. A single continuous filament yarn may have as few as one or as many as several hundred filaments. The types of fibers typically used in filament form include several types of synthetics (e.g., polyester and acrylic), some types of regenerated (e.g., rayon and rubber), and a few natural fibers such as silk. The input material is a sliver and the output is yarn on a large cone or tube<sup>43</sup> Thread bonding is a coating process that some threads may go through to increase the integrity of the construction. Thread bonding is a source of HAPs and is covered by the description in Section II.5.1.2.7 (Polymeric coating of supporting substrates).

During the spinning process, synthetic fibers are often lubricated to aid in future handling or processing. These lubricants can be added to the fiber after converging or to polymer chips prior to melting and extruding. Some of these lubricants include finishes and antistatic agents, the composition of which varies with type of fiber and intended end use.<sup>44</sup>

#### **II.5.1.1.5 Fiber, Yarn, and Thread Dyeing (Potential HAP source).**

Although dyeing is a wet process, textiles can also be dyed in any of several different steps in the dry processing stage. Dyeing can be done using batch or continuous processes.<sup>45</sup> See Section II.5.1.2.2 on dyeing for more details.

Fiber dyeing is typically done in a stock dyeing machine where tightly-packed fibers are placed in a cage with perforated sides (or top and base), which is placed in a large vat. Dye solution is pumped through the fiber mass. The process is costly and has low productivity and is used mostly on woolen materials for certain effects.<sup>46</sup>

Various batch or continuous processes can be used for yarn dyeing. For example, skein dyeing (used for high-bulk yarns such as carpet yarns and for hand-knitting yarns) is done in batch, atmospheric pressure machines, where yarn is dyed in skeins. Another example is package dyeing, which is done in pressurized, batch machines, where yarn is dyed in package form, by being wound onto perforated cores through which dye is pumped. Advantages of the package dyeing method include savings in energy, water, and space, and lesser labor handling. Other methods for yarn dyeing include beam dyeing, indigo dyeing, slasher (warp) dyeing, and space dyeing.<sup>47</sup> Chain (tow) machines are used to dye yarn continuously (manmade fibers).

For manmade fibers, the polymer itself can be imparted with color even before yarn or fabric manufacture. Dope dye machines are used to melt dye polymer before extrusion into fiber.<sup>48</sup>

#### **II.5.1.1.6 Yarn preparation and Slashing (Potential HAP source).**

Yarn preparation involves processes that improve the quality of woven or knitted fabrics produced from the yarn. In preparation steps, yarns will be inspected, cleared for defects, lubricated (if needed), and tensioned. Other steps to prepare yarn for weaving include warping, a process where single packages of yarn are transferred to an even sheet of yarn representing hundreds of ends, and

then wound onto a large cylinder called a warp beam. Warp yarns (in addition to other preparation requirements) need to sustain their elongation and flexibility during the weaving process. Knitting yarns or filling yarns used in weaving, do not have this requirement. This requirement necessitates a process called slashing or sizing, which is the application of a chemical sizing solution to warp yarns prior to weaving to protect them against snagging or abrasion that could occur during weaving. Figure II.5-4 is a schematic of a typical slashing range, indicating potential sources of HAP emissions. Slashing is necessary as long as the warp is in tension; to eliminate the need for slashing, there have been some efforts to develop weaving processes with less tension,<sup>49</sup> although these processes are likely to be much slower.

The objectives of slashing are to strengthen, smooth the outer surface, and lubricate the yarn.<sup>50</sup> The chemical nature of the size applied is dependent on the yarn substrate and the type of weaving being used. The three main types of size currently used are natural products (starch), fully synthetic products (e.g., PVA), and semisynthetic blends (e.g., modified starches and carboxymethyl cellulose or CMC). In addition to these, auxiliary chemicals (lubricants, adhesives, additives, etc.) and water or a solvent are often added. PVA can be applied in pure form (with additives) or blended with natural substances, such as starch.<sup>51</sup>

The sizing operation is done on a large range called a slasher using pad/dry techniques.<sup>52</sup> The slasher contains different sections that take up yarn from the warp beam and pass it through a size box that contains the aqueous sizing solution. Squeeze rolls remove excess solution and the yarn then passes through a drying unit that usually consists of steam-heated cans (drying cylinders) or an oven. After being dried, the warp threads are separated and wrapped on a loom beam to form a sheet to fit the width of the loom. At one facility, the size mixture is cooked in a separate room and pipes transfer size solution to size boxes in slashers.<sup>53</sup> New sizing technologies include high-pressure squeezing, hot melt sizing, and foam sizing.<sup>54</sup>

**HAP emissions:** The primary source of air toxics from slashing is methanol from PVA size, typically applied to synthetics (although it adheres to natural fibers as well). Toxic additives are likely to be minor contributors to HAP emissions. The methanol emissions can arise either from the size cooking operation and/or from the slashing or sizing process - the distribution is unclear, although it will depend upon the temperature at which the size is cooked, the cooking time, and how often containers (cookers) are opened. One facility doing sizing contends that most of the methanol emissions are likely to be emitted during the size cooking step.<sup>55</sup> There are no HAP emissions from desizing operations or when recycled PVA is used, since at that point the methanol has already been flashed off.

**Control options:** According to the ATMI MACT survey,<sup>56</sup> no add-on air emission controls are being used for PVA and PVA mix slashing operations. A very small number of facilities reported use of fabric filters for other (non PVA) slashing operations. The feasibility of other control technologies has not yet been determined.

There are several factors that affect the required size add-on (and wet pickup) and these include characteristics of the yarn, number of ends and tension of warp, squeeze roll control and conditions, residence time of yarn in the size box, and viscosity of the mix.<sup>57</sup> However, the main P2 option for reducing HAP emissions is to reduce methanol content in the PVA. ATMI members report that PVA with guaranteed methanol contents less than 1% is now available from large PVA

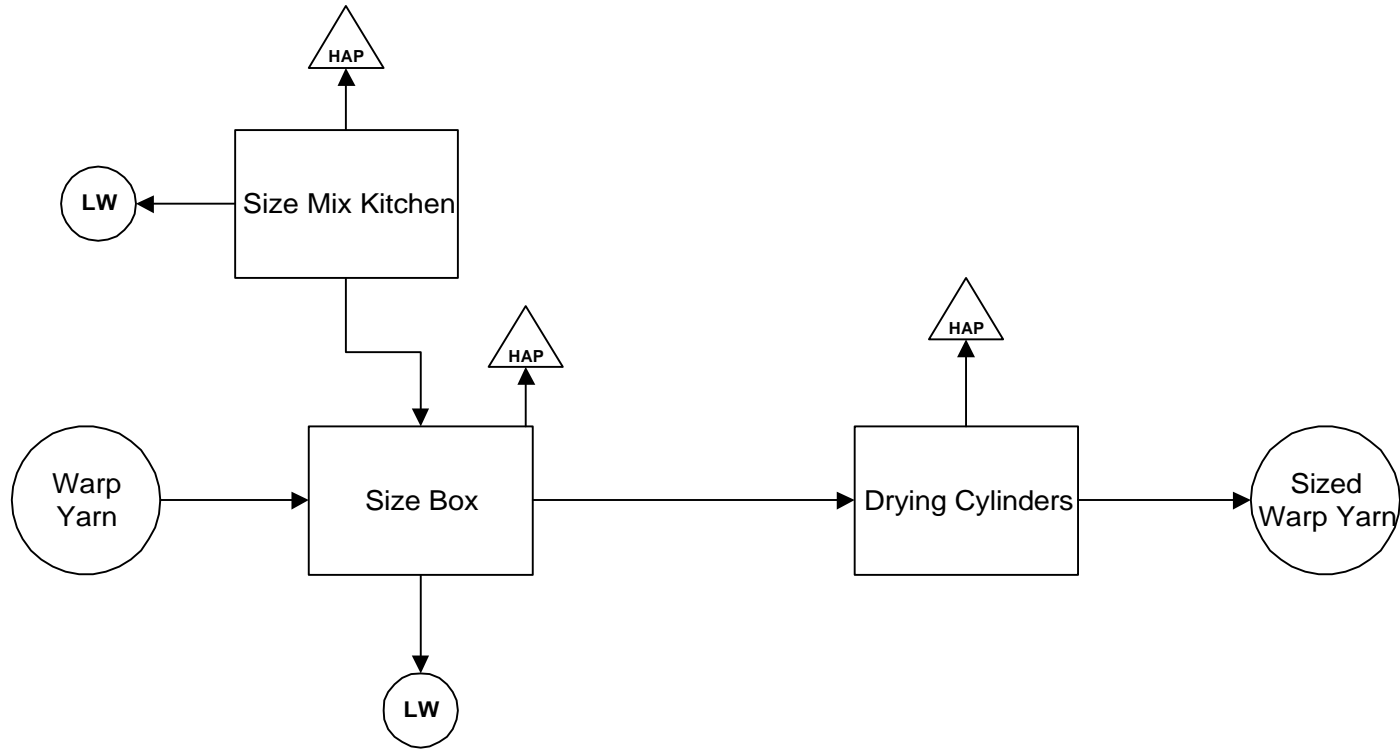

= Potential HAP Air Emission



= Liquid Waste Potentially Containing HAP

Figure II.5-4. Typical Slashing Range

vendors without any premium applied to the price. Most of the PVA supplied by these vendors contains less than 0.5% methanol. Buyers can request certificates verifying methanol contents from at least one vendor. Other quality control methods that can be aimed at reducing quantities of size used include preparing correct quantities of size, proper selection of size mix, scheduling runs, eliminating unnecessary additives, and avoiding leaks and spills.

During desizing operations, PVA can sometimes be recovered for reuse (such as by using membrane filtration), although this is easiest in integrated mills where both sizing and desizing operations take place (so that the recovered PVA does not need to be shipped to another facility) and is not feasible when size blends are used. However, the PVA recovery procedure is also expensive and not economically feasible for small volume operations. There is not enough information on other possible substitutions (since size mixes achieve specific results), although natural products such as starch cannot be applied to synthetic yarns. In fact synthetic sizes are recommended for use because natural materials cause water pollution (BOD/COD) problems.<sup>58</sup>

#### **II.5.1.1.7 Weaving.**

Weaving is a dry operation, but is normally done in buildings maintained at high humidity to increase flexibility of the yarn and minimize breakage.<sup>59</sup> Weaving is performed on different types of looms, which vary in speed and methods used to transport fill yarns. The warp yarns are arranged so that they run lengthwise and the fill yarns run crosswise (at right angles to warp threads), so that these two yarns can be interlaced to impart a weave to the fabric. The warp yarns are wound on to large metal cylinders called beams and these are the yarns that normally pass through a sizing solution (see Section II.5.1.1.6 on slashing). The fill yarn is transported either by a shuttle or by shuttleless methods, such as using high-speed jets of water, air, or projectiles.<sup>60</sup>

Both natural and manmade fibers (or blends) can be woven. Also relevant in woven fabric design are considerations like the type of yarn, fabric construction and design required.<sup>61</sup> Carpets are also woven (1.7% of market share) using the same basic principles as in fabric weaving, although there are variations in methods (such as to manufacture velvet carpets) and equipment used. Woven carpet often has a backcoating of latex or a resinous compound to improve tuft bind and 'hand'. See Section II.5.1.2.8 for more information on backcoating.

#### **II.5.1.1.8 Knitting.**

In knitting, fabric is formed by interlocking or intermeshing loops of one or more sets of yarns. Knitting is performed using one of two processes - weft and warp knitting, each is done on several different types of machines. In weft (or filling) knitting, loops are formed by needles knitting the yarn across the width of the fabric. In warp knitting, loops are formed by needles knitting a series of warp yarns fed parallel to the direction of fabric formation.<sup>62</sup> Knitting is used for producing sweaters, hosiery, and other types of fabric. Knitting can use any type of fiber or yarn. Carpet constructions like knitted, needlepunch, braided, etc. account for 6.7% of the U.S. market.<sup>63</sup> Knitted carpets are very uncommon and Mohawk Industries is believed to be the only knitted carpet manufacturer in the U.S.



#### **II.5.1.1.9 Tufting.**

Tufting involves inserting additional yarns into the fabric to create pile fabric. In modern tufting machines, hollow needles carry and insert the yarn through a substrate cloth, which can range from a thin backing to heavier material. Tufting is used for apparel fabrics, upholstery, and blankets, although most tufting machines are used for carpets. In the US, 91.6 percent of all carpet is produced using tufting.<sup>64</sup> The primary backing into which the tufts of yarn are inserted is a woven or non-woven fabric. Pattern attachments can be added to basic tufting machines.<sup>65</sup>

#### **II.5.1.1.10 Nonwoven manufacturing (Potential HAP Source).**

In addition to the fabric formation methods described above, manmade fibers can be processed into fabric using nonwoven techniques. Nonwovens are typically used in industrial applications and are a growth segment in the textile industry. Nonwovens are essentially sheet or web structures made by bonding and/or interlocking fibers, yarns, or filaments using mechanical, thermal, chemical, or solvent means. Figure II.5-5 is a schematic of a typical nonwoven manufacturing operation. Nonwovens have several performance advantages such as moldability, and are typically engineered for specific uses, such as geotextiles, blankets, diapers, electrical insulation, and filters. Nonwovens can be homogenous fiber-web or netlike structures or can be laminates/composites. Typical fibers used in making nonwovens include polyester, polypropylene, rayon, and wood pulp.<sup>66</sup>

Raw materials in making nonwoven fabrics are supplied either as synthetic polymer chips or as fibers. If a polymer chip is used, it needs to be melted and extruded, whereas fibers need to be opened, separated, and cleaned (using the same methods as in spun yarns). Nonwovens can be manufactured using different processes: dry lay; wet lay; spun bond; and melt spun. Each one of these processes involves web formation and sheet/web entanglement (bonding). The web formation typically involves a series of mechanical processes to feed in the fiber, open/blend, and to comb and straighten it to form a composite web, that varies in size and thickness. In the wet lay process however, the fibers are first suspended in a solvent, which can be water or a chemical solvent. This is followed by web formation, dewatering, and drying. In melt-blown processes, the feed consists of polymer that has been molten using a stream of hot air.<sup>67,68</sup>

After web formation, the sheet is bonded using chemical bonding, thermal bonding, or mechanical entanglement. Examples of mechanical techniques include using needle punching to entangle fibers, using water jets to entangle fibers (spunlaced), or stitching sections of the web (stitch bonded).

Latex resin bonding (chemical bonding) is a common technique. A web, supported on a moving belt or screen, has an adhesive resin called a latex binder applied to it by dipping the web into the latex and removing the excess, or by spraying, foaming, or printing the latex onto the web.<sup>69</sup> Various types of liquid binders can also be used, which include aqueous solutions (e.g., PVA and acrylic latex), organic solvent binders (e.g., N. Rubber and benzene), and water-based emulsions (e.g., urea-formaldehyde, phenol-formaldehyde, PVC, and natural R. latex).<sup>70,71</sup> In addition, the webs can be colored by adding pigment to the latex solutions. However the latex resin bonding process requires large amounts of heat to remove water and thereby dry and set the binder into the

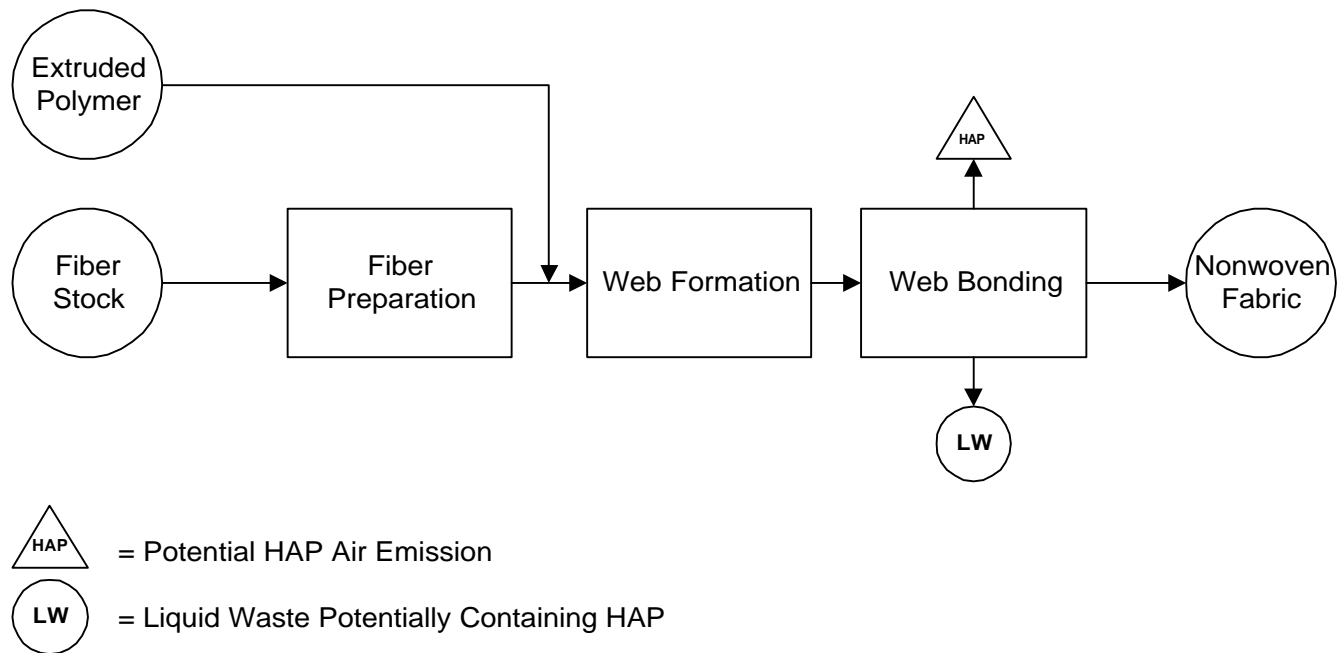

Figure II.5-5. Example Nonwoven Manufacturing Process Flow Diagram

fabric. More heat is needed for binder applied by dipping or printing compared to binder applied by spraying or foaming .<sup>72</sup>

The largest end uses for latex resin bonded staple nonwovens are cover stock, wipers, fabric softener substrate, and interlinings. This class of nonwovens has lost share in these markets over the last decade as thermal bonded, spunbonded, and spunlaced nonwovens replaced resin bonded versions in numerous applications.<sup>73</sup>

In thermal bonding, fiber surfaces are fused to each other either by softening the fiber surface, if it melts at low temperatures, or by melting fusible additives in the form of powders or fibers. The fibers and powders are made from fusible polymers such as polyethylene, polypropylene, and polyester. Bonding fibers and powders can be blended in with the web fibers before the web is formed or they can be sprayed on and into the web with a spray gun. Through-air heating and calendering are two common bonding methods. The through-air method uses hot air to fuse fibers within the web and on the surface of the web to make high loft, low density fabrics.<sup>74</sup> At one facility, the nonwoven manufacturing line includes processes for chopping greige waste materials to be used, shredding, blending, and needling. Some of these fibers are bonded by melting polyester (heaters drop down over the web) at 300°F .<sup>75</sup>

In calender point bonding, the web is drawn between high-pressure, heated cylinders that have an embossed pattern so that only part of the web is exposed to extreme heat and pressure. This type of calendering produces strong, low loft fabrics. Ultrasound can also be used to cause localized fusion and bonding of fibers.<sup>76</sup>

Over 80 percent of the U.S. consumption of thermal bonded carded fabrics is in cover stock. Thermal bonded carded fabrics have also gained share at the expense of resin bonded nonwovens in the interlining market.<sup>77</sup>

Mechanical bonding is the oldest technique for consolidating a web, and is used to enmesh or entangle fibers to give strength to what are usually dry-laid webs. The most common methods are needlepunching and hydroentangling (spunlacing). In needlepunching, barbed needles are punched vertically through the web, hooking tufts of fibers through it and bonding it in the needlepunched areas. The hydroentangled process uses fine, high velocity jets of water to impact a fibrous web and cause the fibers to curl and entangle about each other. Binder is not required, though a small amount of binder may be added to increase fabric strength and dimensional stability or to make them liquid repellent on one side. A third mechanical bonding process called stitchbonded uses a continuous filament to sew a web of unbonded fibers into a fabric with a stitch pattern.<sup>78</sup>

Mechanical bonding techniques typically are slower than chemical or thermal bonding. However, they yield advantages in strength and aesthetics. The two largest markets for needlepunched nonwovens are automotive trim and geotextiles. Other major end uses, in order of importance, are coated/laminated fabric backings, bedding and home furnishing materials, filters, interlinings, roofing, and landscape fabrics. Medical packs and gown are by far the largest spunlaced application. Other large uses are wipers and medical sponges. Stitchbonded fabric is used in shoe components, mattress ticking, and coating substrates.<sup>79</sup>

Needle punching is also used to manufacture some nonwoven carpets. The needles used differ in design and function as compared to those used for tufting. This method is not very common and is used primarily for walk off mats and carpet runners.<sup>80</sup> Nonwoven carpets typically require the application of a chemical binder or resin, which acts as an adhesive to bond fibers within the structure. Many binder systems are available and are generally referred to as 'latex'. Once the chemical binder has been applied, the material is heated to evaporate the liquid component and promote curing / film formation.<sup>81</sup>

**HAP Emissions:** In the ATMI MACT survey,<sup>82</sup> 5 facilities reported that they were manufacturing non-woven fabric using an adhesive / chemical process. No controls are being used at any of these facilities. At least one facility reported greater than 3 TPY of methanol emissions (actual) and smaller quantities of other HAPs. The 1995 Toxics Release Inventory (TRI) reports show that there are some facilities with very high emissions of formaldehyde (one facility reported 230 TPY), as well as other HAP compounds including dichloromethane, ethylene glycol, and methanol.

### **II.5.1.2 Wet Processing**

Wet processing includes several steps that involve imparting colors or patterns to the fabric, along with a variety of finishing steps that provide certain desired characteristics to the end product. These finishing steps are important mainly in cotton and synthetic production. For most wool products and some manmade and cotton products (like gingham), the yarn is dyed prior to weaving and the pattern is woven on the fabric. Figure II.5-6 is a generalized flow schematic of typical woven fabric wet processing operations.

#### **II.5.1.2.1 Preparation<sup>3</sup> (Potential HAP source)**

Preparation includes any of several steps that may be taken to clean or prepare the fabric prior to dyeing. Preparation includes, but is not limited to, heat-setting, desizing (woven only), singeing, scouring, bleaching, and mercerization (cotton only).<sup>84</sup> Heat-setting is described in Section II.5.1.1.3 of this document. Different types of equipment and chemicals are used in different preparation steps, and all these steps are not necessarily undertaken for all fabrics. Desizing, scouring, and bleaching operations all involve removal of impurities and can be done on various types of washers and steamers. The specific chemicals used vary from a simple warm water wash to use of surfactants, chelates, alkali, and oxidizing agents. Drying operations are generally done using ovens or tenter frames.<sup>85</sup> Figure II.5-7 shows a schematic of a typical fabric preparation range that encompasses these operations.

Singeing involves passing the full width of a fabric under tension over open gas flame burners (singer), which remove projecting hairs to clean the fabric and reduce pilling.<sup>86</sup> Singeing is an optional step and does not involve the addition of any chemicals. No HAPs are emitted from this process.

---

<sup>3</sup>As suggested through the ATMI MACT survey, preparation and dyeing have been separated and solvent scouring is included as a preparation step. ATMI results also include those for carpet manufacturing - although these cannot always be identified through the survey.

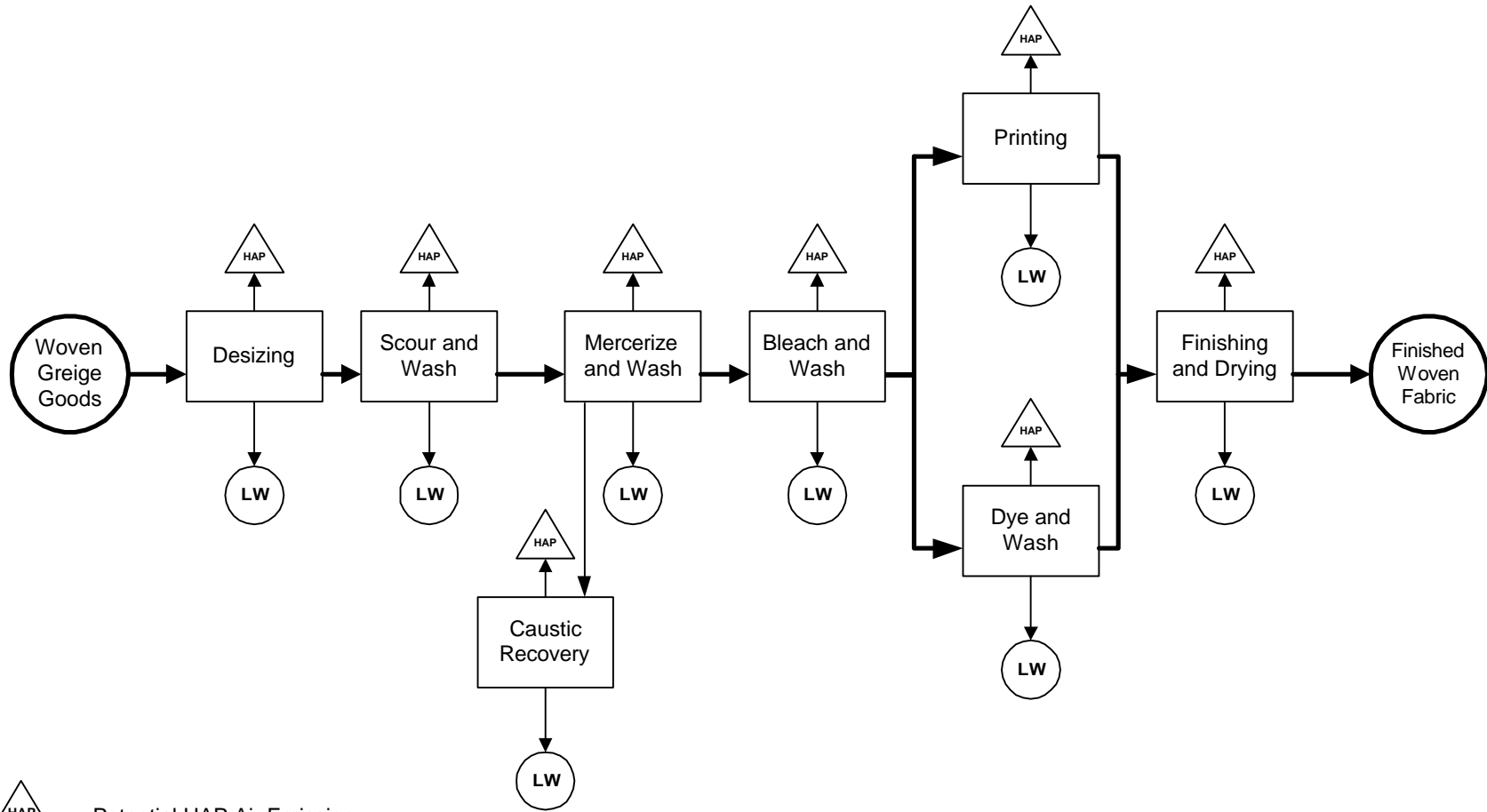

△ HAP = Potential HAP Air Emission  
○ LW = Liquid Waste Potentially Containing HAP

Source: Reference 83

Figure II.5-6. Woven Fabric Finishing Mill

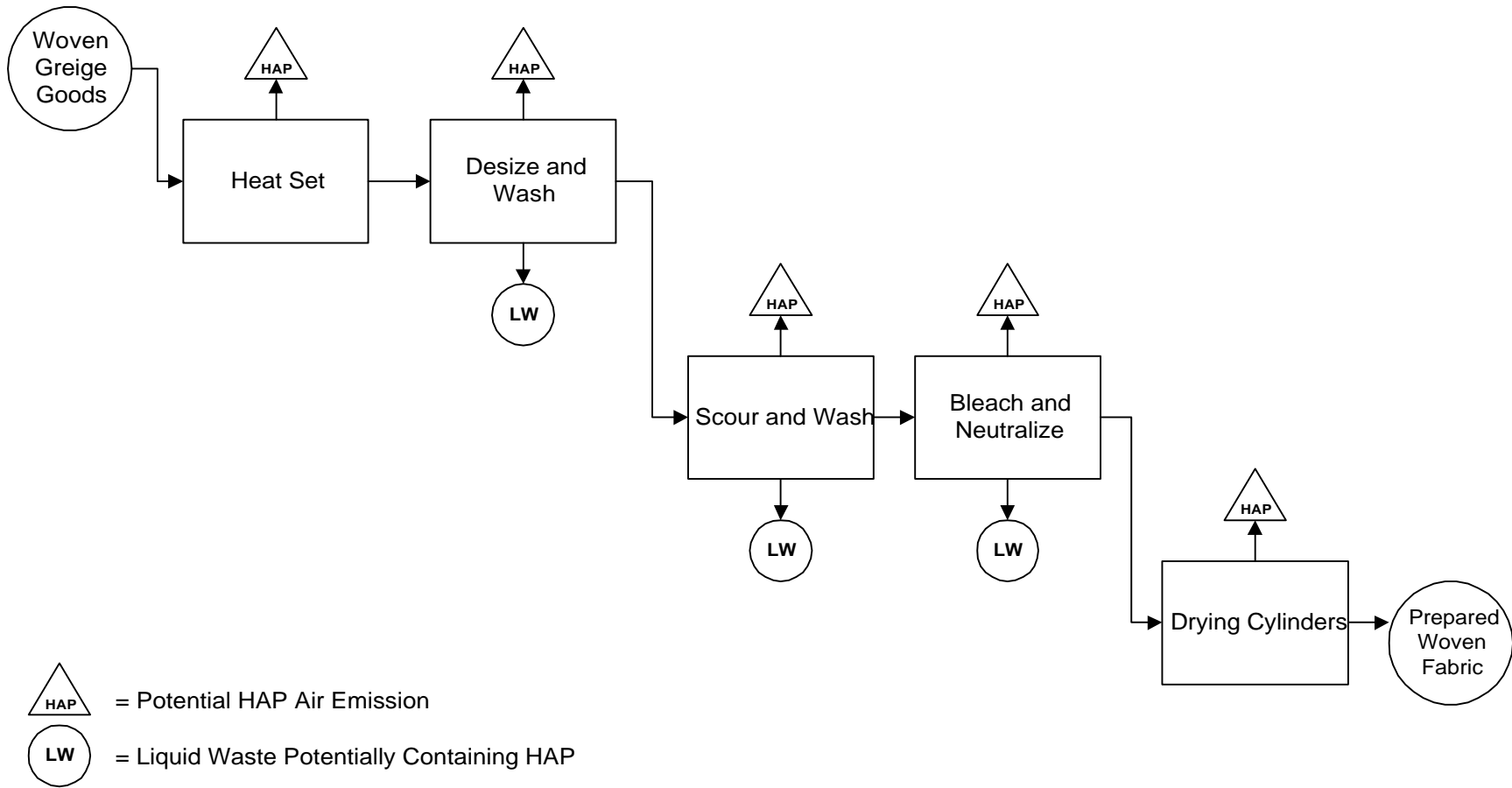

Figure II.5-7. Typical Fabric Preparation Range

Desizing, scouring, and bleaching are typically done in close succession, which sometimes makes it difficult to distinguish where one process starts and the other ends, especially in batch operations. Various types of washers and steamers are used for these processes, and the chemicals used vary according to what is being removed/washed from the substrate. Chemicals used can include enzymes, chelating agents, surfactants, acids/bases, or oxidizing agents. Processes can be batch or continuous. Saturators are used for chemical application, steamers are used as reactors, and washers are used for washing off chemicals or impurities. In batch processes, chemical application, reaction, and washing are performed in the same vessel (drop/fill), using machines such as jet dyeing machines, becks, jigs, etc.. Washing is a major component of desizing, scouring, bleaching, and mercerizing. It can be done open width or with roped fabric, usually in a series of washers, with the application of direct or indirect heat. Preparation can also be carried out by cold pad/batch methods which involve impregnating the fabric with chemical and allowing it to sit for extended lengths of time (16-24 hours) at room temperature. <sup>87,88</sup>

Desizing is done to remove sizing chemicals that were applied to warp yarns prior to weaving. This is usually the first process in a woven-fabric dyeing and finishing plant. Different removal methods are used, based on the type of size that was applied to the yarn. For example, enzymes can be used for starch removal, and hotwater/detergent/soda ash (alkali) for PVA removal. <sup>89</sup> No HAPs are likely to be emitted from this process. One facility <sup>90</sup> desizes fabric by holding it in a chemical box for 25 minutes in a solution of caustic soda (NaOH), surfactants (non-HAP), and hydrogen peroxide. Another facility does not use a wet desizing operation for their glass fabrics, but instead puts fabric through a heat cleaning or caramelizing process where the fabric may be carried through furnaces at temperatures up to 1180°F to burn off size and binder under an open flame after which the fabric may be kept in batch ovens (at 680 - 720°F) for several days. <sup>91</sup>

Once the protective coating has been removed, the fabric must be cleaned to remove other impurities. Scouring is a cleaning process that removes impurities (dirt, grease, etc.) from fibers, yarns, or cloth. Scouring typically uses alkali to saponify natural oils and uses surfactants to emulsify and suspend nonsaponifiable impurities. <sup>92</sup> For example, synthetics are typically scoured with hot detergent to remove processing oils (spin finishes). In the case of wool, more than half the weight of the fabric is removed as impurities after scouring. <sup>93</sup> Solvent scouring is relatively uncommon, although in the ATMI MACT survey, <sup>94</sup> some facilities did report using this process. HAPs will be generated from this process if solvent scouring is done. One facility <sup>95</sup> scours fabric in a J-box, where it is held for 25 minutes in a aqueous-based scouring system, after which it proceeds to a series of wash boxes.

Carbonizing is done only for wool fabrics and involves treatment with sulfuric acid to remove vegetable matter. The acid reduces vegetable matter to carbon, which is removed by mechanical action during dusting, followed by neutralizing. <sup>96</sup>

Bleaching is typically done using hydrogen peroxide, along with other additives, on cotton, silk, wool, jute, and some synthetics (rarely done on synthetics). Fabrics that will be dyed dark shades are usually not bleached. The objective of bleaching is to decolorize naturally present pigments into whitened fabric, without damaging the fabric. Fabric is bleached in a steamer, J-box, typically for around 25 minutes, <sup>97</sup> or a beck/jig at 203-212°F. In general, chemicals used are oxidizing agents, although certain reducing agents may also be used. An example of a bleach (other than hydrogen peroxide) used on cotton is sodium hypochlorite. Other chemicals used in the process

can include agents to help stabilize the peroxide, such as sodium silicate and other surfactants and chelates (to bind metal). If the fabric is white, it may be neutralized with acetic acid before finishing.<sup>98</sup> No HAPs are emitted from this process.<sup>99,100,101</sup>

Mercerization is an optional and relatively uncommon process, done only on cotton fabrics, for various purposes such as improving dye affinity/uptake, improving strength, etc. Mercerization can be carried out on yarns or loom-state, desized, scoured, or bleached fabrics. The procedure involves treating the fabric or yarns under tension with a strong caustic solution (sodium hydroxide, surfactants) in a mercerizer, allowing time for mercerization to occur, after which it is rinsed off and dried.<sup>102,103,104</sup> Some facilities recover and reuse this caustic.<sup>105</sup> No HAPs are emitted from this process.

Drying is an optional step in preparation.<sup>106</sup> Presumably fabrics to which chemicals are not applied do not need to be dried (e.g., if they are only heat-set). One facility dries the fabric over drying cans as the final preparation step.<sup>107</sup>

**HAP sources:** Sources of HAP emissions vary and will generally be from stacks from tenter frames and curing ovens used for drying and heat-setting operations. The specific pollutants vary according to the type of substrate, the end product, and desired properties of the end product. According to the ATMI MACT survey results,<sup>108</sup> solvent scouring and heat-setting (and 'other' operations like desizing and mercerizing) are the preparation steps that have the potential to result in or contribute to major HAP emissions. A few facilities reported large quantities of HAP emissions from bleaching, but it is likely that those emissions better fit in the solvent scouring category. According to ATMI, this error could have occurred as it is often difficult to segregate the different preparation steps since they are typically done sequentially. Also, as shown in Figure II.5-7, there are several sources of wastewater and there is still uncertainty as to how the HAPs entering the preparation operations are partitioned between air emissions and wastewater, and how much HAP is emitted in the latter case.

Survey respondents reported small amounts of various HAP chemicals such as formaldehyde and vinyl acetate are emitted in the bleaching step. Higher emissions (over or around 10 TPY) are reported for glycol ethers and methanol. Both solvent and non-solvent scouring result in small quantities of emissions of various HAP chemicals including 1,4 dioxane and formaldehyde. Companies doing 'other' preparation steps report emissions of greater than 5 TPY of glycol ethers during desizing and mercerizing operations. The EPA<sup>109</sup> discusses potential impurities (such as metals on cotton and pentachlorophenol on wool) that could result in air emissions in subsequent wet finishing operations, but metal emissions were only reported in trace quantities in the ATMI survey.

In an air emission assessment study conducted at a textile finishing plant,<sup>110</sup> Georgia Tech researchers analyzed direct stack measurements under normal operating conditions for different preparation steps, including scouring and bleaching. Only small quantities of formaldehyde (.06 TPY) and VOCs (1.68 TPY) were measured.

**Control options:** According to the ATMI survey,<sup>111</sup> most (~ 75 - 95%) facilities do not use any air emission controls during preparation steps. Most of the controls that are employed were installed to control particulate emissions (mists/opacity) from tenter frames. For example, for the bleaching



and scouring operations, controls such as fabric filters, demisters, scrubbers, cyclones, and wet electrostatic precipitators (ESPs) are being used. A small number of facilities report the use of incinerators/afterburners in 'other' operations categories.

P2 options for preparation steps typically include activities such as rejecting incoming greige goods with contaminants. Chemical dosing systems and automated mix kitchens can be used to optimize chemical use.

**II.5.1.2.2 Dyeing (Potential HAP source).**

Dyeing is the application of color to the whole body of a textile material with some degree of colorfastness. Textiles are dyed using continuous and batch processes and dyeing may take place at any of several stages in the manufacturing process (i.e., prior to fiber extrusion, fiber in staple form, yarn, fabric, garment). Most of textile dyeing is done in finishing departments of basic textile manufacturing facilities, although there are also several commission dyehouses. From an environmental perspective, dyeing has typically been viewed as a wastewater issue due to the large quantities of water, chemicals, and auxiliaries (such as salt) used.<sup>112,113,114</sup> Figure II.5-8 includes a depiction of a typical fabric dyeing operation.

Dyeing is essentially a mass transfer process where the dye diffuses in solution, adsorbs onto the fiber surface, and finally, within the fiber. Dyeing is complicated by the fact that there are many sources of color variations, such as dyes, substrate, preparation of substrate, dyeing auxiliaries (such as salt) used, and water. Processing variables such as time, temperature, and dye liquor ratio (pounds of dyebath to pounds of cloth) also affect dyeing results. There are hundreds of dyes within several dye classes (see Table II.5-1), each of which exhibits different results when applied to different types of fabric. There is also a lot of variability within different classes of fabric. For example, DuPont produces more than 500 types of polyester.<sup>116,117</sup>

Table II.5-1 Major Dye Classes and Substrate Fibers	
Class	Fibers
Acid	Wool, silk, and nylon
Azoic	Cotton and cellulose
Basic	Acrylic, certain polyesters
Chrome	Wool, silk, nylon
Direct	Cotton, rayon, other cellulosic
Disperse	Polyester, acetate, other synthetic
Fiber Reactive	Cotton and other cellulosic, wool
Naphthol (azoic)	Cotton, rayon, other cellulosic
Mordant (obsolete)	Natural fibers (pretreat with metals)
Pigment	All (requires binders)
Solvent	Synthetic (rarely used in commerce)
Sulfur	Cotton and other cellulosic
Vat	Cotton and other cellulosic

Reference 115.

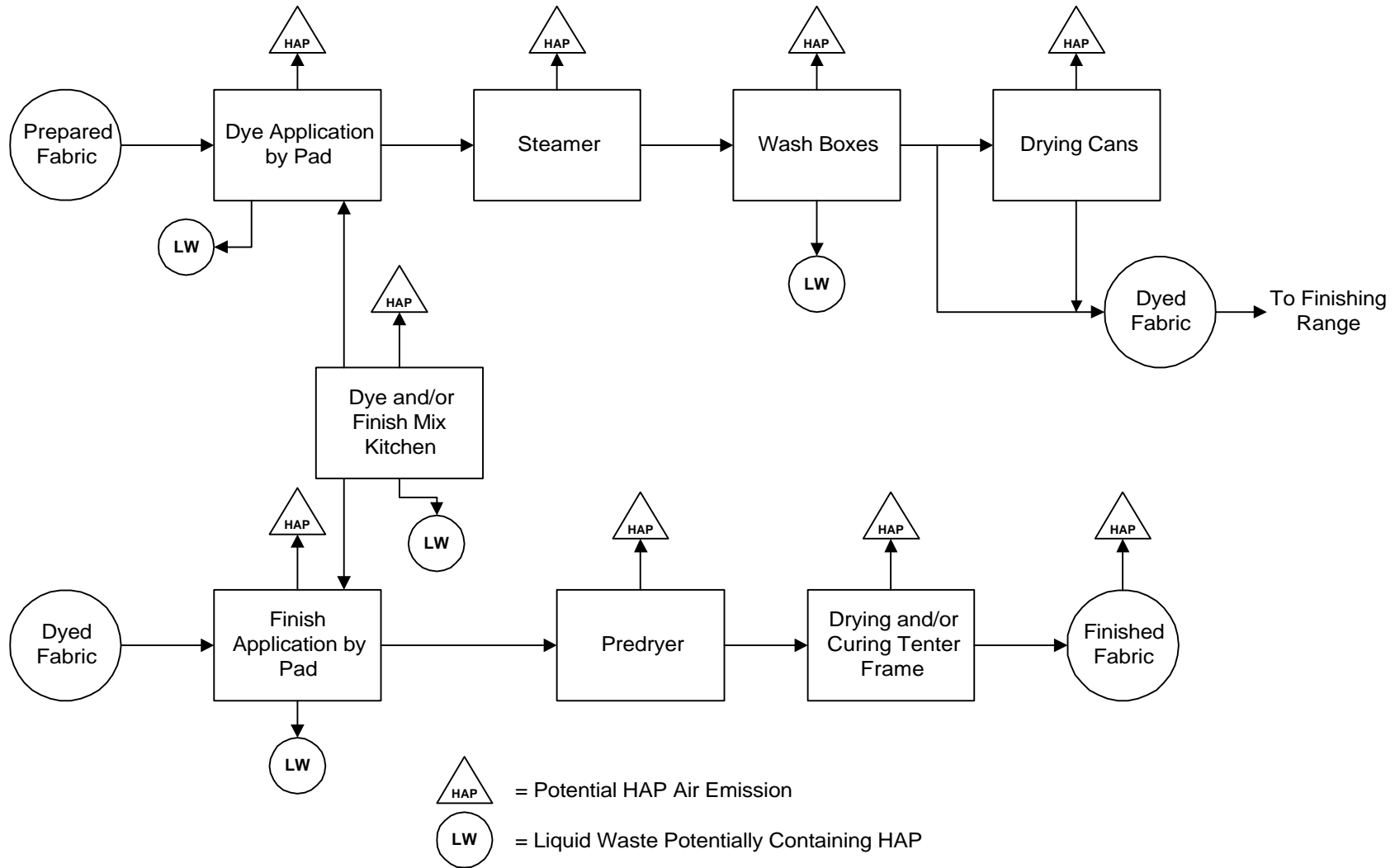

Figure II.5-8. Typical Fabric Dyeing and Finishing Ranges

Various types of dyeing machines are used for both continuous and batch processes. See Figure II.5-9 for examples and brief descriptions of the main types of dye machines in use.<sup>119</sup> Every dye system has different characteristics in terms of versatility, cost, tension of fabric, use of carriers, weight limitations, etc. Dyeing systems can be aqueous, non-aqueous (inorganic solvents), or use sublimation (thermosol, heat transfer). Hydrophilic fibers such as cotton, rayon, wool, and silk, are typically easier to dye as compared with hydrophobic fibers such as acetate, polyesters, polyamides, and polyacrylonitriles.<sup>120</sup>

The four basic steps in the dyeing process are: dissolving or dispersing dye; diffusing dye onto the fiber surface; absorbing dye onto the fiber surface; and diffusing dye into the fiber. Batch dyeing involves moving the dye liquor through the goods or moving the goods through the dye liquor. The textile material is immersed in the dyebath during the entire period of dyeing. In batch dyeing, a certain amount of textile substrate, usually 220 to 2200 lbs, is loaded onto a dyeing machine and is brought to equilibrium or near equilibrium with a solution containing the dye. Once immersed in the dyebath, because the dyes have an affinity for the fibers, the dye molecules leave the dye solution and enter the fibers over a period of minutes to hours. At one facility, reactive dye applied to cotton fabric by pad in a batch dye range rotates on a turning station on an A frame overnight to set the dye.<sup>121</sup> In the dyeing process, auxiliary chemicals and controlled dyebath conditions (mainly temperature) accelerate and optimize the action. The dye is fixed in the fiber using heat and/or chemicals after which the substrate is washed to remove unfixed dyes and chemicals. There is a trend to use of lower liquor ratios (pounds of dyebath to pounds of cloth) in batch dyeing, which lends benefits such as faster heating/cooling and less waste. Batch equipment can usually be purchased as atmospheric (operated below 212°F) or pressurized (operated up to about 280°F) machines.<sup>122,123,124</sup>

Continuous processes typically consist of dye application, dye fixation with chemicals or heat, and washing. Continuous dyeing is usually used for long runs of polyester/cotton fabrics and involves immersing fabrics in a relatively concentrated dyebath for short periods. Textiles are fed continuously into a dye range at speeds usually between 540 and 2690 feet per minute and a concentrated solution of dyes and chemicals (held in pads) is moved evenly and uniformly to the goods with thorough penetration. A pad mangle helps apply pressure to squeeze dye solution into the fabric and the dye is usually diffused or fixed by heating in a steamer or oven. Dye fixation on fiber occurs much more rapidly in continuous dyeing as compared to batch dyeing. After fabrics are dyed, they are dried in ovens or tenter frames.<sup>125,126,127,128</sup>

At one facility,<sup>129</sup> polyester-cotton blends are dyed continuously by first passing fabric through a dye-pad for application of a disperse dye for the polyester. Then the fabric goes through a series of ovens to dry and evenly fix the dye onto the fiber. The fabric first goes through a pre-dryer to reduce moisture from 70% to 20-30%, then to a hot flue oven (fabric temperature in both ovens does not exceed 212°F until completely dry), further passes through predry cans (around 300°F, although the fabric itself does not reach this temperature) to remove the rest of the water (to ensure level dyeing), and finally through a Thermosol oven operating at around 400°F to swell the polyester so that the dye penetrates and forms a mechanical bond. To dye the cotton fiber, either vat, naphthol, or sulfur dye is used. The fabric goes through another dye application and steamer after which it passes through a series of washboxes to remove unbonded or unreacted dye before being dried over drying cans.

Machine	Type of Substrate	Width	Typical Configuration Capacity/Limitations/Advantage
---------	-------------------	-------	--

Stock	Fiber	500 kg	Fiber is dyed inside of perforated tubes.
-------	-------	--------	---

Same machine can be used for package and beam dyeing.

Large quantities of dyed fiber can be blended for color consistency.

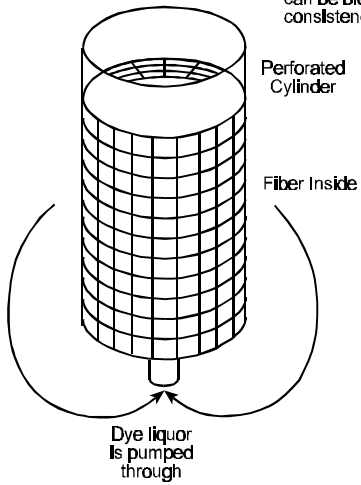

Stock Dyeing

Machine	Type of Substrate	Width	Typical Configuration Capacity/Limitations/Advantage
---------	-------------------	-------	--

Package	Yarn	550 kg	Yarn is stationary, bath is pumped through.
---------	------	--------	---

Same machine can be used for beam or stock dyeing.

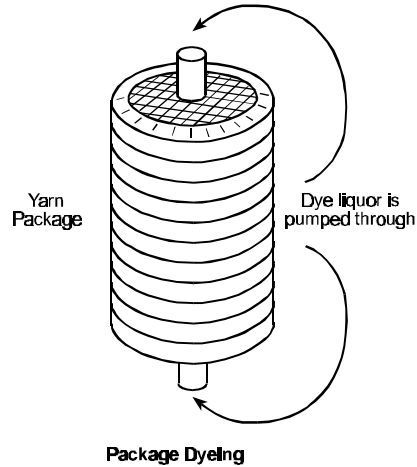

Machine	Type of Substrate	Width	Typical Configuration Capacity/Limitations/Advantage
---------	-------------------	-------	--

Skein	Yarn	100 kg	Yarn is dyed in hanks.
-------	------	--------	------------------------

Used for bulky acrylic and wool yarns.

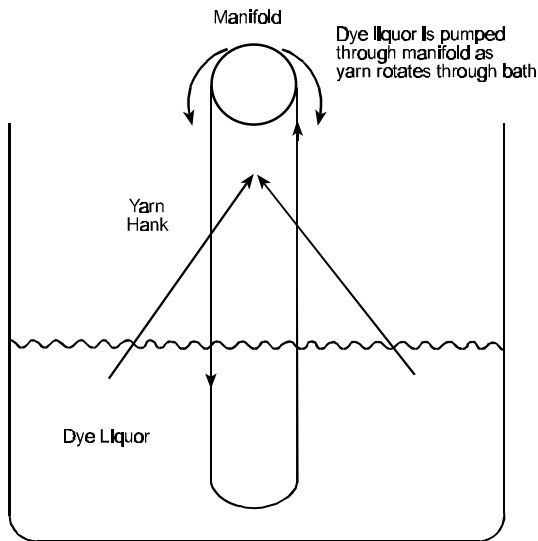

Skein Dyeing (end view)

Source: Reference 20

Machine	Type of Substrate	Width	Typical Configuration Capacity/Limitations/Advantage
---------	-------------------	-------	--

Dope	Polymer melt prior to yarn formation	Continuous	Pigments are added polymer before extrusion into fiber.
------	--------------------------------------	------------	---

Figure II.5-9 Dye Machines

Machine	Type of Substrate	Width	Typical Capacity/Limitations/Advantage
Beck	Fabric	Rope	900 kg Very versatile—can be used almost universally.  Good for repair work.  Causes substantial mechanical working of goods.  Can cause creases and cracks in delicate, lightweight goods (e.g., nylon, acetate).

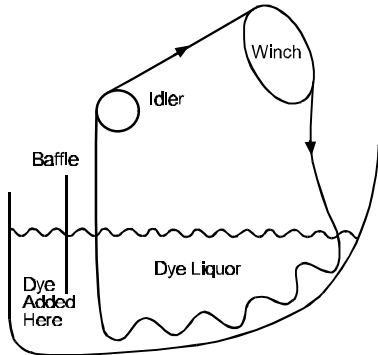

Beck Dyeing (end view)

Machine	Type of Substrate	Width	Typical Capacity/Limitations/Advantage
Jet	Fabric	Rope	500 kg Capable of high pressure and temperatures.  Fabric is handled gently.  Fabric and bath both are in motion.

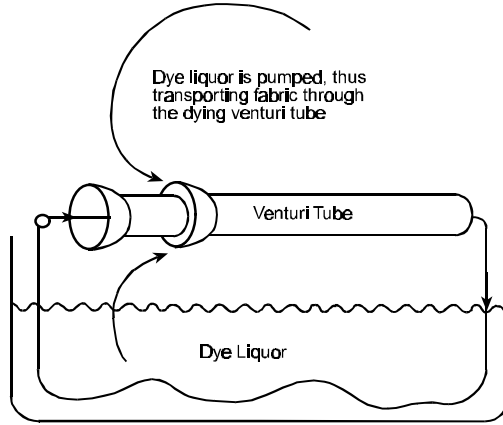

Jet Dyeing

Machine	Type of Substrate	Width	Typical Capacity/Limitations/Advantage
Beam	Fabric	Up to 5 meters	1,000 kg Fabric is handled flat, thus reducing creases and cracks in delicate goods.  Optimum for lightweight, wide, and delicate goods.  Fabric is stationary, bath is pumped through.  Same machine can be used for stock or package dyeing.

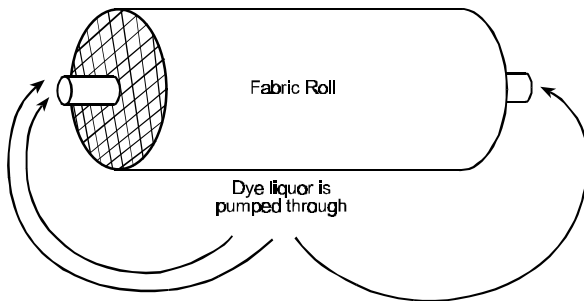

Beam Dyeing

Machine	Type of Substrate	Width	Typical Capacity/Limitations/Advantage
Jig	Fabric	2 meters	250 kg Fabric is handled flat reducing creases and cracks.  Does not run disperse dyes very well.  Too much tension for weft knits.

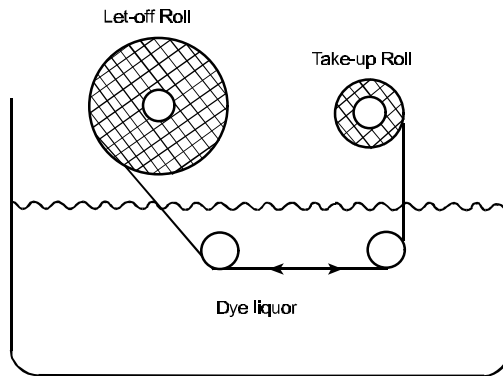

Jig Dyeing (end view)

Figure II.5-9 (Continued)

Machine	Type of Substrate	Width	Typical Configuration Capacity/Limitations/Advantage
Paddle	Fabric or Products		100 kg For products such as hosiery, rugs, etc.

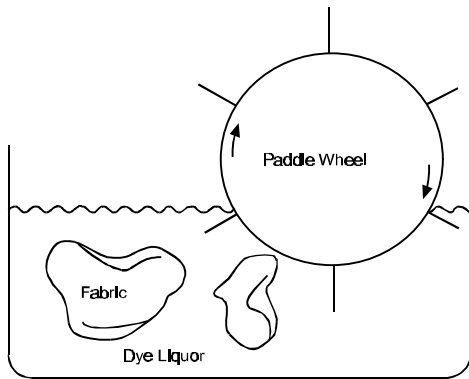

Paddle Dyeing

Machine	Type of Substrate	Width	Typical Configuration Capacity/Limitations/Advantage
Garment (Rotary)	Products (Garments)		500 kg Garments are dyed cutting and sewing.

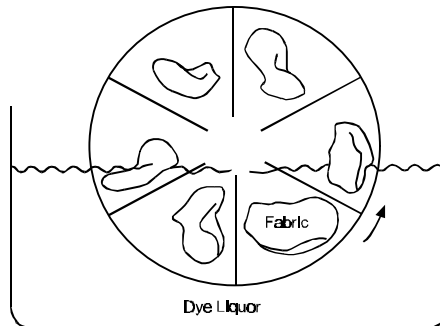

Rotary Garment Dyeing

Machine	Type of Substrate	Width	Typical Configuration Capacity/Limitations/Advantage
Chain (Tow)	Yarn		Continuous Used to dye yarns continuously.

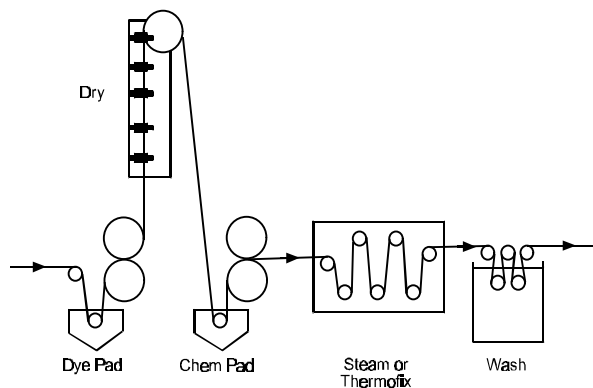

Continuous Dye

Machine	Type of Substrate	Width	Typical Configuration Capacity/Limitations/Advantage
Continuous	Fabric	Up to 3 meters	Continuous Best economics for long runs. Poor economics for short runs.

Several types of fixing methods include steam, chemical reactions, thermo fix, and cold batch methods.

Not effective for general purpose repair work.

The only type of dyeing machine which can run pigments.

Too much tension for knits may be a problem

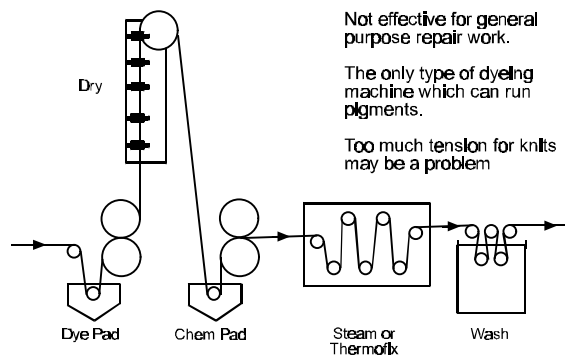

Continuous Dyeing

Figure II.5-9 (Continued)

Various classes of dyes can be used, e.g, disperse for synthetics and direct for cellulose (see Table II.5-1). Dyes used in the textile industry are mostly synthetic and are derived from coal tar and petroleum-based derivatives. Dyes are sold as powders, granules, pastes, liquid dispersions, and solutions. Not only are dyes applied in different ways, they also impart color using different mechanisms.<sup>130</sup> Dyes can be classified according to chemical constitution or method of application. Dyestuffs can work on principles of electrostatic bonding, covalent bonding, or physical entrapment. For example, acid dyes work through the mechanism of electrostatic bonding, whereas disperse dyes work by physical entrapment.<sup>131</sup> Different dye classes exhibit different affinities depending on the type of fiber, although even dyes within the same classes can show wide affinity variations. They also exhibit different properties such as their fastness under end use conditions such as light, laundering, or dry cleaning.

Various combinations of chemical auxiliaries and process conditions (temperature and pressure) may be used to better fix the dye on the fabric or impart specific characteristics. For example, a dye bath may contain the dyestuffs along with appropriate auxiliaries such as wetting agents and also specific chemicals such as acetic acid or sodium hydroxide.<sup>132</sup> For indigo dyeing of yarn to be used for denim, one facility adds a chelating agent and caustic soda to the dye. For sulfur dyes used on cotton, they add a reducing agent that activates the dye to form a chemical bond.<sup>133</sup> Available information<sup>134</sup> on HAP contents in dyes from facility site visits can be summarized as follows:

- Vat Dyes: One facility reports that ethylene glycol in these dyes has been substituted with non-HAP glycols like propylene glycol or diethylene glycol.
- Naphthol dyes: These dyes may be a small source of HCl emissions as this is needed as an auxiliary to help with dye-coupling with cellulose. According to one facility, most of the HCl goes into wastewater where it is neutralized.
- Sulfur dyes: Certain colors may contain organic HAPs. Although glycol ethers and ethylene glycols (in sulfur dyes used for cotton) may not be needed in the dyeing process itself, they act as a humectant (keep the dye from drying out) and cannot be removed from the dyes.
- Disperse dyes: Some of these dyes used for dyeing polyester do not contain HAPs.
- Reactive dyes: Some of these dyes for cotton do not contain HAPs or VOCs.

The use of higher temperatures and superatmospheric pressures have reduced the need for dye carriers (chemical accelerants) that were required at lower temperatures for the use of disperse dyes on synthetic substrates, such as polyester.<sup>135</sup> Although some studies have been done to examine dyes (classified by color groups) for evidence of hazardous nature based on molecular structures,<sup>136</sup> in general, such characterizations are difficult to do for individual dyes. Also, no studies have been completely comprehensive in examining all known dyes, which leaves the vendors as important sources of environmental information on dyes. However, in the future dyes are likely to become more proprietary, with an associated loss of information for users.<sup>137</sup>

The ATMI MACT survey<sup>138</sup> identified two separate categories for batch and continuous dyeing, each covering fiber, yarn, and fabric dyeing (separately). In the ATMI survey, most companies reported dyeing temperatures ranging from 100 to 400°F, (a few reported temperatures below 100 or over 400°F). Almost all the continuous dyeing was reported as being done at atmospheric pressures, although some facilities reported pressure and vacuum dyeing as well. Most of the

batch dyeing was being done using pressurized machines, although several facilities reported using atmospheric machines, especially for fabric dyeing.

**HAP emissions:** Dyeing contributes to HAP emissions, which result mostly from the types of chemical auxiliaries used, rather than the dyestuffs. The chemical auxiliaries required are related to the type of dyeing processes and substrate being dyed. Other factors that affect HAP emissions from dyeing include the stage in the dyeing process where chemicals are introduced (the temperature to which the chemicals will be subjected) and the shade of color (deeper shades require more dye pick-up as compared with pastels). For example, one facility<sup>139</sup> claims that no HAP emissions result from their use of indigo or black sulfur dyes, although other colors have the potential to result in ethylene glycol and glycol ether emissions.

HAP emissions from dyeing will generally occur from stacks from tenter frames and curing ovens used for drying operations. The pollutants vary widely according to the type of substrate, the end product, and desired properties of the end product. ATMI survey respondents reported several different types of HAP emissions, however, most of these were in relatively small quantities (less than 1TPY). All emissions reported for continuous fiber dyeing, batch fiber dyeing, and batch yarn dyeing were less than 1 TPY. Higher emissions were reported for continuous yarn and fabric dyeing, and batch fabric dyeing. Types of emissions reported in quantities greater than 1 TPY include the following HAPs: ethylene glycol, formaldehyde, glycol ethers, 1,2,4 trichlorobenzene, toluene, methanol, and biphenyl. The survey does not help identify the specific sources of these chemical emissions.

ATMI<sup>140</sup> stresses that the issue of the fate of glycol ethers needs to be addressed since these compounds are highly soluble, biodegradable, and with low vapor pressure. These properties, according to ATMI, make it likely that the majority of glycol ethers remain in wastewater (depending on the temperature of the dye liquor) and biodegrade within 3 days, thus making most of the current estimates of glycol ethers air emissions highly inflated. One facility points out that since the sulfur dyes they use for cotton (containing glycol ethers) are not exposed to more than 212 °F, the glycol ethers are likely to be mostly removed in wastewater rather than emitted to the air. They currently estimate only 10% as being emitted into air, and consider that a conservative figure.<sup>141</sup> Dye carriers that are used are typically high boiling organics.

In an air emission assessment study conducted at a textile finishing plant,<sup>142</sup> Georgia Tech researchers analyzed direct stack measurements under normal operating conditions for different process steps, including dyeing using vat disperse and sulfur dyes. Although VOCs were measured in quantities greater than 10 TPY, most emissions of formaldehyde and glycol ethers were measured at less than 1 TPY. Glycol ether emissions from sulfur dyes were estimated at 2.47 TPY through the stack tests, as opposed to  $3.6 \pm 3.3$  TPY through the mass balance.

**Control options:** According to the ATMI MACT survey,<sup>143</sup> most companies are not using any add-on controls with dyeing processes, especially for dyeing fiber, where only a demister may be used. For yarn and fabric dyeing processes add-on controls include demisters, cyclones, scrubbers, and fabric filters employed to control particulate emissions (mists/opacity). No incinerators / afterburners were reported to be in use.



There is not enough information on dyes and the specific sources of the HAP emissions that would help identify possible P2 options. However, chemical dosing systems and automated mix kitchens can be used to optimize dye use. Other process modifications such as use of low bath-ratio dyeing systems and dyebath reuse help conserve chemicals and thus reduce subsequent resultant air and wastewater emissions.

#### **II.5.1.2.3 Carpet Dyeing (Potential HAP source).**

Carpet dyeing involves essentially the same basic mechanisms and chemicals discussed above in the fabric dyeing section. However, some of the dyeing techniques used may be different, mostly a result of the stage at which dyeing is done and the nature of the substrate. Figure II.5-10 includes a schematic of typical carpet dyeing process steps. Carpet dyeing techniques can be classified into two major categories: pre-dye and post-dye. Pre-dyeing refers to dyeing loose fiber or yarn prior to manufacturing the carpet. Post-dyeing, also called piece dyeing, refers to dyeing after the tufting process. Each dyeing technique in these major categories has its advantages and disadvantages in terms of economics and flexibility.<sup>144</sup>

Examples of pre-dye techniques used include stock dyeing, skein dyeing, space dyeing, and solution dyeing. Wool and acrylic are fibers that are typically dyed prior to spinning (stock dyed). Stock dyeing involves putting a cleaned fiber bundle in a large dyeing kettle and applying color to the whole mass. Less than 1 percent of carpets in the U.S. are dyed using this method. Skein dyeing is typically used where small quantities of specific colors may be needed, such as in highly patterned carpets. Skeins of yarn are hung on poles and dipped into dyestuff which is circulated into the carpet fiber. This method represents about 5 percent of carpet dyeing in the U.S. Space dyeing counters streaking problems or provides a special effect by dyeing only every 1/4 inch (for example) along the length of a yarn. Space dyeing represents about 2 percent of carpet dyeing in the U.S. Polypropylene is an example of a fiber that is dyed primarily (almost 100%) while in its liquid phase, prior to extrusion. This is termed as solution dyeing. Nylon is also sometimes solution dyed. Solution dyeing typically limits colors available.<sup>145</sup>

Post-dyeing techniques include beck dyeing and continuous dyeing (see Section II.5.1.2.2). Nylon carpeting is typically dyed after the manufacture of (greige) white carpet. Beck dyeing is an important method used for piece dyeing of carpets (especially nylon). It essentially involves the carpet being passed via a reel through a large tub containing the dye liquor, which is pumped and circulated to provide color evenness. Continuous dyeing is the most popular technique in large carpet mills and represents about 50 percent of all carpet dyeing in the US. Continuous lengths of carpets are sewn together and passed through a dye application area after which they are steamed to fix the dye, and subsequently washed to remove excess dye and dried. Other attachments and innovations are used for dyeing patterns or for special affects.<sup>146</sup>

In two plants doing continuous dyeing of carpets, approximately 0.075 lb of dye chemicals were applied per pound of carpet. Liquid, acid based dyes were used along with various defoaming and leveling agents, wetters, softeners, acids, stain-block agents, and fluorochemicals. The carpet is first steamed to open up fibers and allow even dyeing, after which gum and dye bath chemicals are applied. The carpet is then steamed again to set in the dyes. Finally a spray of stainbock and/or Scotchgard® may be applied after which it is dried in an oven. The maximum carpet temperature was given as 240°F in the dryer, where the maximum temperature was about 300°F.<sup>147,148</sup>

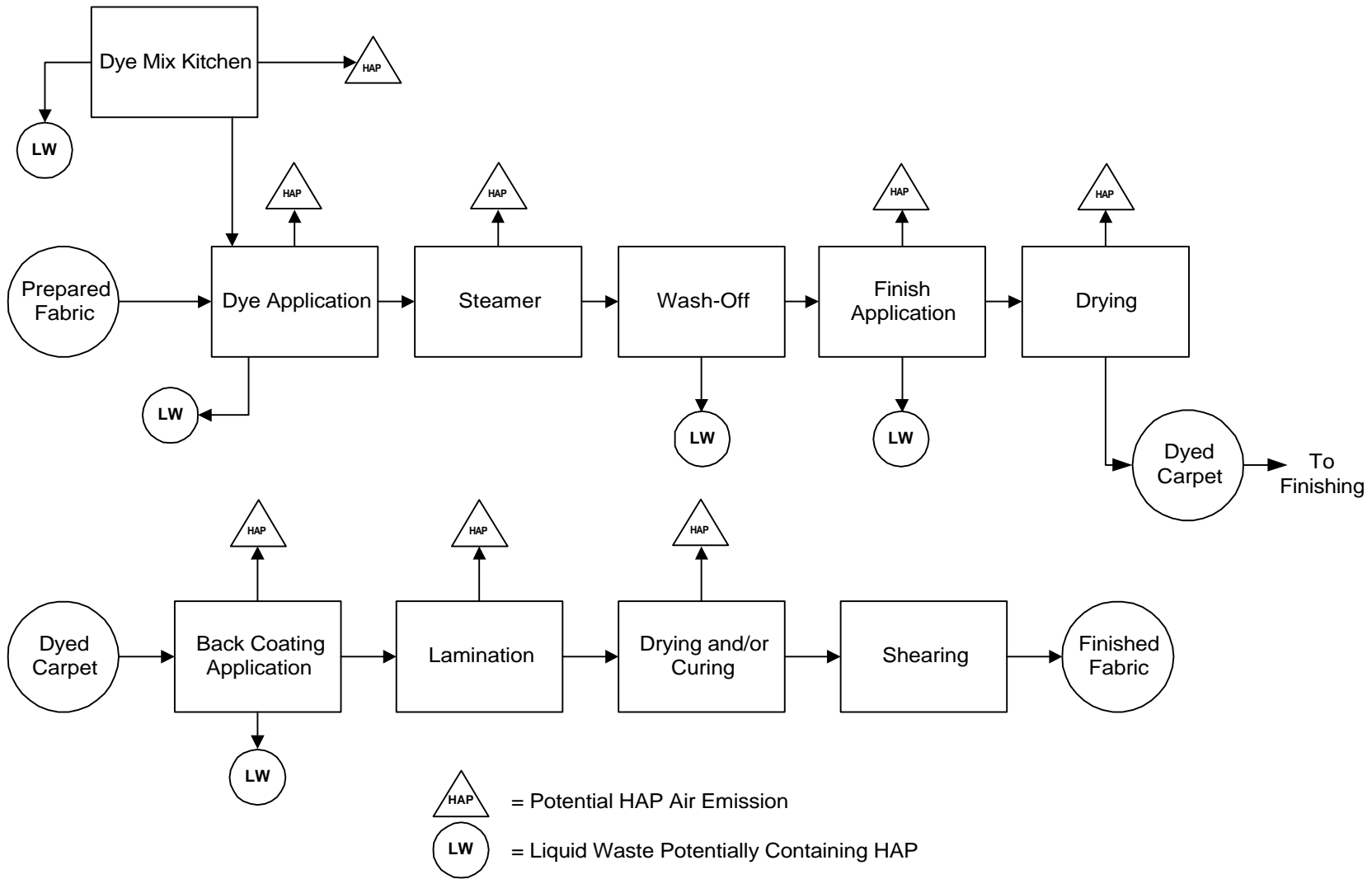

Figure II.5-10. Example Carpet Dyeing and Finishing Process Flow Diagram

Carpets can also be printed using processes similar to those for paper and fabric. Typical printing techniques (see Section II.5.1.2.4 on fabric printing) used for carpets include screen printing techniques (flatbed and rotary printing) and jet printing. Jet printing sprays the dye directly onto the carpet and does not use screens. After a carpet has been printed, it is steamed to exhaust the dye onto the carpet, after which residual dye is washed off and vacuumed, and finally, the carpet is dried.<sup>149</sup>

**HAP emissions:** Since the ATMI survey did not separate out the carpet and rug manufacturing operations, there is no information on HAP emissions specifically from carpet dyeing. However, sources, emissions, and control / P2 options are likely to be the same as in the case of fabric dyeing (Section II.5.1.2.2).

In an ongoing project for air emission assessments for carpet manufacturing processes, Georgia Tech researchers have analyzed direct stack measurements under normal operating conditions for different process steps, including continuous carpet dyeing.<sup>150</sup> About 200 samples and 11 stack flow measurements were taken on multi-color lines of two carpet dye plants to assess emissions of VOCs, aldehydes and ketones, and dissolved gases. Total potential HAP emissions are estimated at 0.7 TPY based on a nominal production rate of 13,000 yd<sup>2</sup>/hr. The researchers do caution that results were based on limited plant studies. The next phase of this research will look at emissions from beck dyeing operations at carpet mills.<sup>151</sup>

#### **II.5.1.2.4 Printing (Potential HAP source).**

While dyeing is preferred for solid colors or simple patterns, in most other cases, printing techniques are used. Printing processes involve the use of colors, usually in the form of a paste, which are applied to fabrics in patterns. Fabric is treated with steam, heat, or chemicals to fix the color. Different types of printing ranges are used. The types of chemicals used include pigments (greater than 70 percent of printed fabric) or dyestuffs, and auxiliaries (such as softeners, thickeners, and cross-linking agents). Pigments have some similarities to dyestuff, but also differ from them in many ways, for example, unlike dyes, they are insoluble in water and common solvents.<sup>152</sup>

Textile printing can be done on printing ranges using different techniques, the most common ones being rotary screen printing (75 percent), flat-bed screen printing (3 percent - mainly used for custom work), engraved roller printing, and heat transfer printing.<sup>153</sup> Each technique has its own advantages and disadvantages. Figure II.5-11 is a schematic of a typical rotary screen printing range, indicating potential HAP emission and liquid waste (potentially containing HAP) sources.

The steps in the printing process include preparation of print paste, printing of fabric, drying, dye fixation (by heating or steaming), and washing off. Rotary screen printing, the most commonly used technique, is a continuous process where the fabric is glued to a blanket that moves under rotating screens that impart pattern to the fabric. Printing pastes can contain several different ingredients other than the dyes or pigments. These include thickeners, softeners, binders, cross-linking agents (urea/formaldehyde resins), and other auxiliary chemicals like emulsifiers and defoamers. If printing is done using dyestuffs, print paste constituents will differ.<sup>154,155</sup>

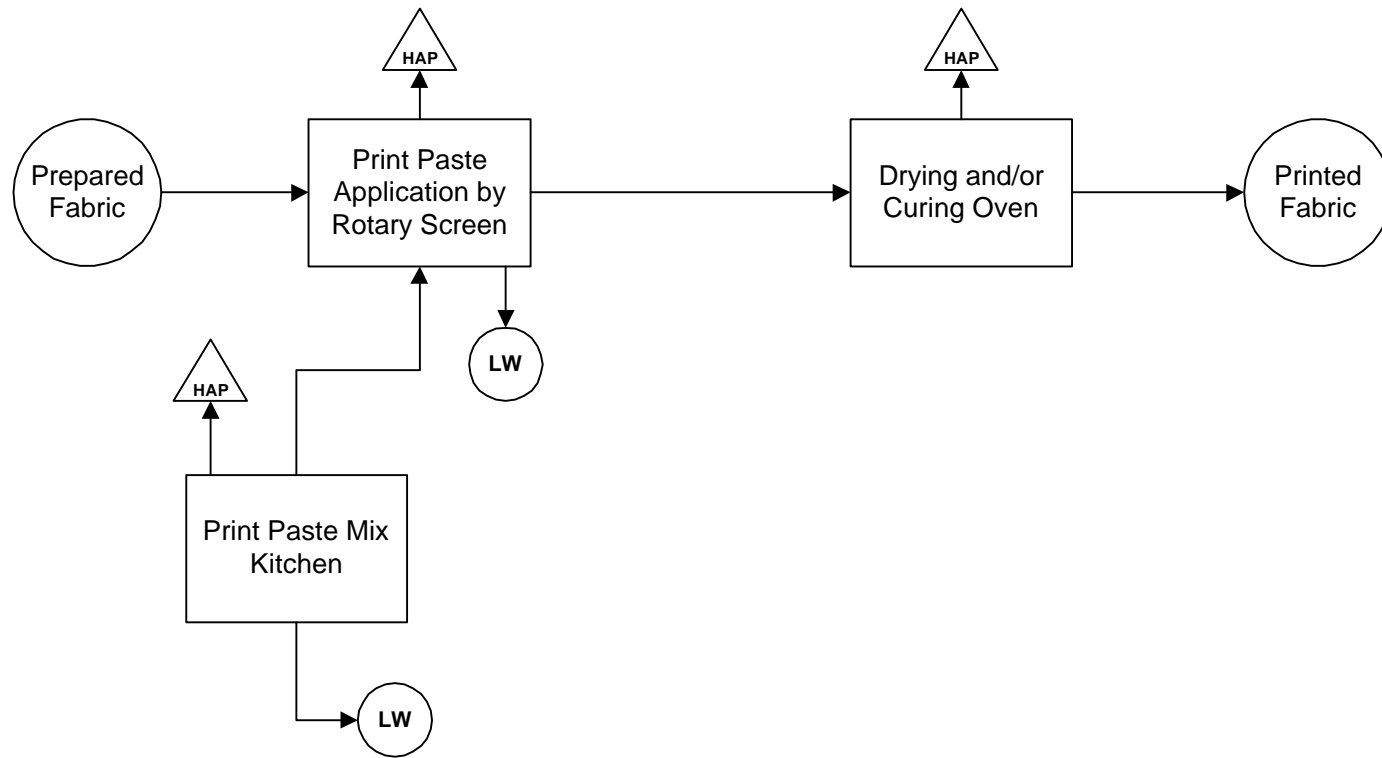



 = Potential HAP Air Emission  
 = Liquid Waste Potentially Containing HAP

Figure II.5-11. Typical Rotary Screen Printing Range

**HAP emissions:** The specific pollutants depend on the printing technique employed and the chemicals used. A possible source of HAP emissions is solvent-based print pastes - however these have almost completely been replaced by polymeric thickeners (a small percentage of solvent - around 2 percent - may be needed to produce the correct rheology).<sup>156</sup> A few printers still use oil-water emulsion systems as thickeners and some specialty print shops still use solvent-based printing inks. Four facilities reported solvent-based pigment printing in the ATMI MACT survey.<sup>157</sup> Use of urea-formaldehyde crosslinking agents can also result in HAP emissions, as can the glue used to make the fabric adhere to the printing blanket. As in other operations, HAPs from printing are likely to be emitted during drying and curing operations. Another potential source of solvents is cleaning operations (machine cleaning and screen cleaning).

ATMI MACT survey<sup>158</sup> respondents reported a variety of HAPs emitted at rates under 1 TPY. Emissions greater than 1 TPY were reported both under the solvent-based and water-based printing categories for HAPs including: glycol ethers, ethyl benzene, ethylene glycol, formaldehyde, vinyl acetate, styrene, cumene, and xylene. It is unclear whether the emissions reported in the water-based printing category were mistakenly put there. No surveyed facility reported emissions as much as 5 TPY for any single HAP from printing operations. However, these contribute to total HAP emissions at facilities performing other operations as well as printing. The survey itself does not reveal the specific sources of these emissions or the reasons for differences in emissions between different facilities. Process operations are done at temperatures below 400°F and several facilities reported process temperatures of below 100°F. At least one facility reported the printing operation as being done using a pressurized machine, although in the process description they stated dyeing, finishing and printing, in which case they may have been referring to the dyeing/finishing operations.

**Control options:** The ATMI survey results revealed that there are no HAP emission controls used with any printing operations. Some States have VOC content limits based on the CTG for vinyl coating, which refers to any printing or decorative topcoat applied over vinyl coated fabric or vinyl sheets. The CTG recommended limitation is 3.8 lb VOC / gallon of coating (minus water). Printers can opt to use polymer print pastes (not varsol based) and other nonvolatile alternatives. At least one firm reports that it refuses to purchase printing products with photochemically reactive chemicals, in order to stay within permit VOC limits.<sup>159</sup>

Good management practices related to color shop operations and print paste handling, as well as possible substitutions for cleaning operations, could help in reducing HAP emissions. There are also various emerging technologies for reducing water pollution and chemicals used (which would translate to lesser air emissions), such as ink jet printing and transfer printing.<sup>160</sup> However, inkjet printing is very slow and heat transfer printing, while economical for short runs, also is slow and is used primarily for polyester.<sup>161</sup>

#### **II.5.1.2.5 Finishing (Potential HAP source).**

Finishing refers to any operation (other than preparation and coloring) that improves the appearance and/or usefulness of fabric after it has been woven or knitted. Finishing encompasses any of several mechanical (e.g., texturing, napping) and chemical processes (e.g., optical finishes, softeners, urea-formaldehyde resins for crease resistance) performed on fiber, yarn, or fabric to

improve its appearance, texture, or performance. Other than chemical and mechanical, other terms use to categorize finishes include wet or dry and durable or non-durable. <sup>162,163</sup>

The ATMI MACT survey <sup>164</sup> had two categories - one for dry (mechanical) finishing and the other for wet (chemical) finishing. The fabric is usually dried prior to finishing using either convective (hot air) or conductive (heated cans) methods. <sup>165</sup> Chemical finishing can be done on a continuous finishing range (pad and tenter frame). Figure II.5-8 includes a schematic of such a finishing process. It should be noted that various mechanical finishing methods can also be performed during this process, but these are not shown on the schematic as they are likely to be highly varied and can be done at different stages in the process.

At one facility, <sup>166</sup> chemical preparation for finishing is done in 100 to 500 gallon tanks, with the amount of finish prepared being based on pre-established estimates of finish per square yard for specific fabric styles. Almost 170 chemicals are used in different combinations for preparing different types of finishes at the facility. Some fabrics may absorb more finish than others, whereas some fabrics may need to be passed through multiple baths. The facility neutralizes unused finish prior to discharge. At another facility, finishes are applied by pad to fabric after which it is passed 4 to 5 times through a predryer to reduce moisture content from 70% to 20 - 30%. Drying is done in stages to promote even drying across the fabric. Once it has been predried, the fabric is passed through an oven at 300°F to complete the drying. The hottest curing temperatures at this facility are used for resin finishes where curing temperatures may reach 380°F (although fabric will not reach that temperature).

No chemicals are used in mechanical finishing (although ATMI survey respondents report varying quantities of HAP releases from dry finishing as well - sources are unclear). It is important to note that there is no set recipe for the chemical and mechanical finishing chemicals or processes used for any given substrate. These methods are chosen according to desired characteristics of the end product (which vary widely and are market driven) and the firms themselves have some amount of flexibility in the specific processes or chemicals they choose to use for a particular function.

The textile industry uses numerous categories of proprietary chemical speciality products as chemical finishes. Some examples of chemical finish classes include: <sup>167,168,169</sup>

- Resin finishes (permanent press) are used on cotton or rayon to minimize the need to ironing by keeping the fabric smooth after washing and drying. Most resins contain formaldehyde, a HAP, and resins without formaldehyde are typically much costlier (by a factor of 5 to 7 times) and can adversely affect product quality.
- Softeners are used with resins to improve the way the fabric feels by breaking down hardness or stiffness.
- Stain resist finishes are used extensively on carpets and upholstery fabrics. Soil release finishes allow soils and stains to be removed by laundering. One facility <sup>170</sup> reports the use of soil release agents that result in potential ethyl acrylate emissions.
- Water repellants to prevent fabrics from being wet out (breathable, unlike waterproofing agents) include wax, silicone, fluorine and other types of finishes.
- Flame retardant qualities can be achieved by using special fibers or phosphorus-based finishes
- Antistatic agents decrease or eliminate static electricity in textiles.

- Stiffeners give the fabrics body or stiffness. One facility<sup>171</sup> reports using firmers that result in potential vinyl acetate emissions (polyvinyl acetate is used as a handbuilder).

Other examples of types of finishes include anticreasing agents, deodorants, moth resisting agents, oil repellants, rust preventatives, and shrinkage controllers. Some companies use more specialized finishes like electrical finishes and teflon. At one such facility, silane finishes were a source of potential methanol emissions.<sup>172</sup> Although coating and laminating are considered chemical finishing techniques, they are described in Section II.5.1.2.7 of this chapter. Because there are typically a wide variety of choices of chemical finishes that can be used within each finish class, it is often difficult to tag finishes used in certain classes as always toxic or nontoxic. In certain cases, as in the case of permanent press finishes, most of the resins used contain formaldehyde, although low or non-formaldehyde finishes are being developed to suit certain applications.<sup>173</sup>

There are also several different types of mechanical finishing techniques that are used. For example, heat-setting can be done to improve dimensional stability in synthetic fabrics. Shearing involves using rotary blade(s) to trim raised surfaces and reduce pilling. Other examples of mechanical finishing techniques include, but are not limited to, embossing, glazing, sueding, and polishing. Cotton and cotton blends are sometimes sanforized for shrinkage control, during which moisture is applied to fabric and then further subjected to compressive shrinkage and dried.<sup>174</sup> Mechanical finishing processes can sometimes be used in place of chemical finishes to achieve the same results.

**HAP emissions:** The HAP emission sources from finishing are specific chemical finishes that may be applied and then released during drying and curing operations. Examples include formaldehyde emissions through breakdown of crosslinking resin (used for permanent press finishes) if N-methylol linkers are used, glycol ethers from softeners,<sup>175</sup> and methanol as a crosslinking reaction product/wetter. Reference 175 also lists methyl methacrylate as a potential handbuilder impurity, but only one facility in the ATMI MACT survey<sup>176</sup> reported a very small quantity of methyl methacrylate emissions from finishing operations. Other spot removers and machine cleaning solvents can also result in HAP emissions.

In the ATMI MACT survey, most emissions from dry finishing were in quantities less than 1TPY, except for one facility reporting high releases of 1,2,4 trichlorobenzene. Facilities reported several different HAP emissions in the wet finishing category. Emissions in quantities greater than 1 TPY include the following HAPs: 1,2,4 trichlorobenzene, biphenyl, glycol ethers, ethyl acrylate, ethylene glycol, formaldehyde, methanol, styrene, tetrachloroethylene, triethylamine, and xylenes. All companies, other than two or three exceptions, report doing finishing operations at atmospheric pressures. Temperatures range from below 100°F to over 400°F, both for wet and dry finishing.

In an air emission assessment study conducted at a textile finishing plant,<sup>177</sup> Georgia Tech researchers analyzed direct stack measurements under normal operating conditions for different process steps, including finishing using low to zero percent formaldehyde permanent press resins. Fabric was cured on a tenter frame operated at between 340 and 400°F. Emissions estimated from mass balance and stack measurements were similar. Measured formaldehyde emissions were lower than expected from mass balance and ranged from 0.88 TPY to 3.72 TPY as compared to mass balance estimates of  $6.4 \pm 1.1$  TPY. Measured glycol emissions, especially diethylene glycol,

were higher than expected from mass balance, ranging from 1.53 to 4.99 TPY, as compared with mass balance estimates at  $0.92 \pm 0.55$  TPY.

At one facility, all HAPs entering the finishing process are assumed to be 100% emitted to the air because finishing temperatures reach in excess of 300°F. This is not the assumption in cases where the chemical cross-links to the fabric. For example, this facility estimates only 50% of the formaldehyde in resin finish as being emitted to air, because 50% is cross-linked with cotton.<sup>178</sup> Another facility operates their dryers at unusually high temperatures (225 - 800°F), primarily because of the nature of substrates processed. Staff at this facility believe that methanol from their silane finishes (used with glass fibers) would be partially or totally destroyed during the drying step.<sup>179</sup>

**Control options:** According to ATMI MACT survey<sup>180</sup> results, a majority of companies (both for dry and wet finishing operations) do not control emissions. Facilities doing wet finishing use wet and dry ESPs, demisters, fabric filters, and scrubbers and at least 7 facilities use thermal oxidizers (both with and without heat recovery). Control efficiencies were not reported for some thermal oxidizers. Reported efficiencies ranged from less than 50 percent to 99 percent or greater. Industry stakeholders<sup>181</sup> agree that generally afterburners rather than thermal oxidizers would be used on finishing processes for opacity control. Afterburners rarely run at incinerator temperatures; typical operating temperatures would be in the 450 to 525°F range.

Many chemical and mechanical alternatives are available for every finishing operation, but the specific nature and applicability of these is unclear. Some mechanical finishes and design alternatives can avoid chemical processing. For example for softness, enzyme softening of cotton and other mechanical alternatives can be used. Proper use and application of N-methylol crosslinkers can minimize formaldehyde releases. Mechanical finishing (compacting) can also eliminate use of the crosslinker. Some crosslinkers that eliminate formaldehyde are available, but are much more expensive. According to ATMI,<sup>182</sup> the industry has made a lot of efforts to reduce the amount of free formaldehyde in resins, however good substitutes that do not adversely affect the quality of the product are difficult to find. Formaldehyde contents can vary from less than one half of one percent for light weight fabrics to 4 percent for heavy fabrics (melamine-formaldehyde resins), and there is a lot of variability in types of resins. Formaldehyde itself does not affect the product; however, it does affect the properties of the resin itself (manufacturing). Acrylic handbuilders and stiffeners can replace formaldehyde-based handbuilders. There are also various technologies for low add-on finishing, such as sprays, foams, kiss rolls, and ultra high extraction with vacuum. Humidity sensors in drying can optimize dryer performance in terms of energy use, dye migration, and air pollution.<sup>183</sup>

#### **II.5.1.2.6 Carpet Finishing (Potential HAP source).**

Carpet finishing is done after tufting, weaving, and dyeing and includes various mechanical (shearing, brushing) and chemical (application of soil retardant, flame resistant, and antistatic chemicals) processes. The finishing process (as depicted in Figure II.5-10) basically has three operations: the first (backcoating) is a laminating process that serves to cement tufts and fibers to primary backing, after which a secondary backing may also be attached; the second is the application of chemical finishes; and the third is to shear the surface of the carpet to remove fuzz



and loose fibers. The backcoating operation is described in more detail in Section II.5.3.1.2.8 of this chapter.

Chemical finishes are applied to woven carpets following the backcoating process. Tufted carpets are often given dry chemical finishes prior to the backcoating process. Chemical finishes are typically applied by immersion in a finish bath, by spraying the finishes onto the carpet, by foam application, and by transfer from engraved or "kiss" rolls to the carpet pile. After finish application, carpets are usually passed through a drying/curing oven, typically operating at temperatures from 280-325°F.<sup>184</sup>

**HAP Emissions:** The ATMI survey did not separate out carpet finishing from fabric finishing. Researchers at Georgia Tech have completed some emissions tests on carpet finishing funded through the Consortium on Competitiveness for the Apparel, Carpet, and Textile Industry (CCAATI). However, since these focused on the backcoating operation, the results are discussed in Section II.5.1.2.8 of this report. The industry claims that the number and types of finishes used for carpets are not likely to be as numerous and varied as in the case of textile fabrics, and consequently emissions are likely to be lower.<sup>185</sup> However, no supporting information for this statement is available.

#### **II.5.1.2.7 Polymeric Coating of Substrates (Potential HAP source).**

Coating is a specialized chemical finishing technique designed to produce fabric to meet high performance requirements, e.g., for end products such as tents, tire cord, roofing, soft baggage, marine fabric, drapery linings, flexible hoses, hot-air balloons, and awnings.<sup>186,187</sup> Figure II.5-12 is a schematic of a typical polymeric coating range for fabrics. Coatings generally impart elasticity to substrates, as well as resistance to one or more element such as abrasion, water, chemicals, heat, fire, and oil. The substrate itself provides strength (such as tear strength) and can include wovens, nonwovens, knits, yarn, cord, and thread, although woven fabrics are most commonly used.<sup>188</sup>

The major components of a coating process include the following:<sup>189,190</sup>

- Coating preparation
- Fabric preparation
- Fabric let-off
- Coating application onto substrate (including impregnation or saturation)
- Lamination (including the use of adhesives, hot melts, and extrusions) - optional
- Drying and/or curing of coating
- Bonding machine lamination (pressure and heat) - optional
- Decoration machine (embossing or printing) - optional
- Takeup-recovery of carrier film or intertwining webs.

Both the substrates coated as well as the coating itself vary. Any number of different textile substrates can be coated including rayon, nylon, polyester, cotton, and blends.<sup>191</sup> Coating chemicals used vary depending on end use of the coated fabric. Examples of coating chemicals include vinyl, urethane, silicone, and styrene-butadiene rubber. The polymer can be bought in various forms such as chunks, blocks, chips, pellets, or fine powder. However, besides the

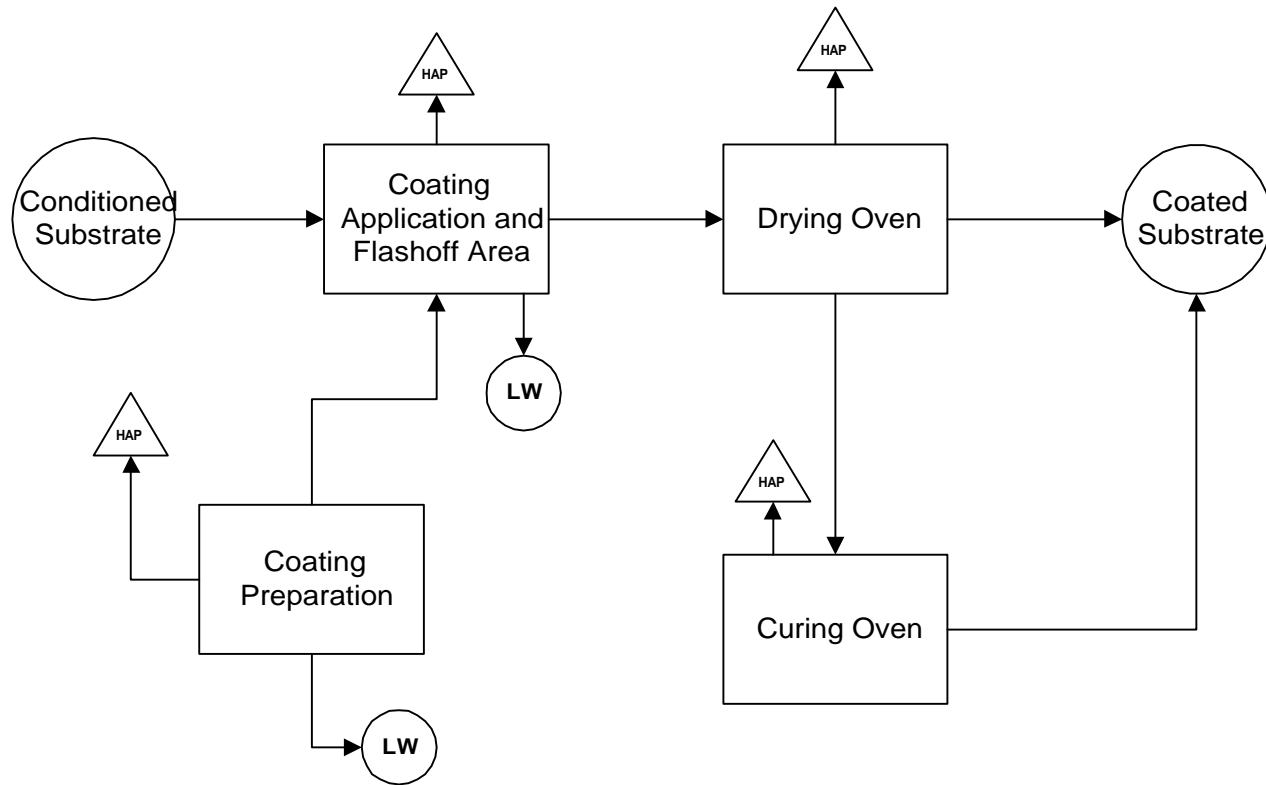



 = Potential HAP Air Emission  
 = Liquid Waste Potentially Containing HAP

Figure II.5-12. Typical Polymeric Coating Range

polymer resins, several other chemicals can also be included in the prepared coating. These include plasticizers to increase pliability (e.g., fatty acids, alcohols), solvents to disperse solids and adjust viscosity (e.g., toluene, xylene, dimethyl formamide, MEK, etc.), pigments, curing agents, and fillers (e.g., carbon black and teflon). Manmade fibers coated with epoxy or phenolic resins are often not immediately cured following application, but are first laid in a mold and then cured under pressure to form a composite structure.<sup>192</sup>

Lamination is a process of using heat, adhesives, and pressure to bond a substrate and plastic film. Also, two or more fabrics or a fabric and a paper substrate may be bonded with an adhesive to form a laminate. The distinction between coating and laminating is that coated fabrics are true composites (e.g., a plastic film on the textile), whereas laminating involves tacking together two or more pre-formed layers (multi-component). A distinction that is made between coating and slashing is that although slashing does involve putting a coating of size on the yarn, the coating is not permanent.<sup>193</sup>

In conventional systems, the latex or other synthetic polymers, in an organic solvent medium, are sprayed on the cloth, and the solvent evaporates, leaving behind the coating.<sup>194</sup> However, coating ranges can use different types of application methods:<sup>195,196</sup>

- Calander coating: This process is typically used for a 95 to 100% solids coating, which is melted and made into sheet form by squeezing through successive pairs of heated rolls. It is used to apply vinyl plastic or thermoplastic rubber to a substrate. An intermediate roller transfers the hot viscous resin onto the fabric.
- Knife over roll coating: A knife is used to uniformly spread coating onto the fabric and control the weight of the coating applied.
- Dip coating: Used when saturation of the substrate is desired, and is used for all cord and thread coating lines. The substrate passes from a roller through a coating reservoir or dip tank, after which roller or wiper blades remove excess coating.
- Roller or reverse-roll coating: Coating material is picked up from a supply bath by an applicator roll and transferred onto the material which is kept in contact using web tension or a rubber backup roll. Excess material is removed by a metering roll. This method is usually used for thin coating layers and is not a typically used for rubber coatings, because these tend to dry on the rollers.
- Others: Several other types of coating applicators are also used, including spray coating and heat extrusion coating.

Table II.5-2 displays typical coating line speeds and dry coating thickness. The typical distance between the coating application point and the oven entrance varies from about 15 cm for knife coaters to up to 1 m for dip or roll coaters. Drying ovens may be vertical or horizontal and range from 4 to 8 feet in width and 20 to 100 feet in height or length. They may be steam heated or direct fired but usually involve some kind of forced air convection systems.<sup>198</sup>

For the purpose of collecting background information on fabric coating, three industry segments have been identified. These segments include cord treatment for general rubber products, fabric coating using dip and dough spreading for general rubber products, and fabric flocking. A brief description of each of these processes follows.

**Table II.5-2 Coating Applicator Parameters** <sup>197</sup>

<b>Coater</b>	<b>Coating Type</b>	<b>Line Speed, meters/min</b>	<b>Dry Coating Thickness m</b>
<b>Knife over roll</b>	Rubber Urethane Vinyl Silicone Acrylic	6.1 - 23	75-500
<b>Dip</b>	Rubber Epoxy Phenolic Silicone Vinyl	1.5 - 40	25 - 2000
<b>Reverse Roll</b>	Urethane	13.7 - 64	25 - 1250

Cords contribute to the tensile strength of finished belts. In the cord treatment process, a nylon, polyester, or aramid cord is unwound from spools and directed into a solvent-based isocyanate primer dip, followed by solvent flashoff in a hot air oven. The applied primer prepares the cord for the next step, a water-based resorcinol, formaldehyde, latex (RFL) primer dip, that creates bonding sites on the cord. Subsequently, the water in the RFL dip is dried by passing the cord through heated oven zones. The last coating operation involves dipping the cord in a solvent-based rubber adhesive tank. Finally, the solvent in the adhesive is removed via an evaporation tunnel, and the coated cord is spooled. Cord treating units treat multiple cords concurrently and are labeled accordingly (e.g., 40-cord treater or 60-cord treater). <sup>199</sup>

Wall components and other segments of hoses, belts, and tires are fabricated from fabric coated using dip and dough spreading procedures. The types of fabrics used in these processes include cotton, cotton/polyester blends, nylon, polyester/nylon, and aramid and have thicknesses ranging from 0.01 to 0.07 inch. Both dips and doughs are solvent-based (often toluene-based) rubber coatings. A "dip" refers to a low-solids content "cement," often containing 70 percent or more organic solvents, while a rubber "dough" designates a higher solids content (20 to 45 percent) formulation. In a dip spreading operation, fabric is unrolled, immersed in a dip pan, passed through a set of rollers that remove excess coating, and dried in an oven. In a dough spreading operation, fabric is unrolled into the spreader machine, where dough is rolled on top of the fabric. A doctor blade or knife regulates the thickness of the application. After the dough permeates the fabric, it is dried in an oven. <sup>200</sup>

Flocking is a method of cloth ornamentation in which finely chopped fibers are applied to adhesive coated surfaces. Flocking is done on textile substrates as well as on other substrates such as paper, plastic, metal, and foam. The majority of flocking uses finely cut natural or synthetic fibers. In the flocking process, the fabric substrate is coated with an adhesive, the fine particles are applied, and the adhesive is dried in an oven. The flocked finish imparts a decorative and/or functional

characteristic to the surface. The variety of materials that are applied to numerous surfaces by different flocking methods create a wide range of end products. The flocking process is used on items ranging from retail consumer goods to products with high technology military applications.<sup>201</sup>

**HAP emissions:** VOC or HAP emissions from coating systems result primarily from vaporization of solvents during coating and drying/curing (although as Figure II.5-12 suggests, there are other more minor sources as well). Trace amounts of plasticizers and reaction by-products (cure-volatiles) may also be emitted.<sup>202</sup> Solvent-based coating systems are expected to be among the largest emitters of HAPs like methyl ethyl ketone (MEK) and toluene in this source category. HAPs will likely be emitted during application and drying/flashoff operations and also possibly during mix preparation (filling, coating transfer, intermittent activities such as changing filters, and the mixing process if proper covers are not installed). In addition, HAP emissions from solvent storage tanks occur during filling and from breathing losses.<sup>203</sup> Several types of HAP emissions are reported in the ATMI MACT survey<sup>204</sup> at facilities, doing both solvent-based and water-based coating. Waterborne coatings are defined as those containing more than 5% water by weight in the liquid fraction. Table II.5-3 presents the types and quantities of HAP emissions from facilities with coating operations, for HAP compounds reported to be emitted in quantities greater than 1 TPY.

At least one facility doing water-based coating reported greater than 100 TPY of toluene emissions, which could be an error (actually for solvent-based coating). All facilities, with one exception, report performing coating operations at atmospheric pressures and typically at temperatures greater than 300°F (although some facilities report temperatures below 100°F as well).

**Table II.5-3. HAP Emissions from Facilities with Coating Operations**

Coating System	HAP emitted	Emissions (TPY)
Solvent-based	MEK	1 - 25
	methylene chloride	50 - 163
	methyl isobutyl ketone	0.2 - 47
	toluene	0.1 to 85
	xylene	0.3 to 315
	vinyl acetate	5
	vinyl chloride	5
Water-based	ethyl acrylate	5
	ethylene glycol	3
	formaldehyde	1
	glycol ethers	75
	methanol	15
	phenol	8
	styrene	4
	vinyl acetate	1.6
	xylene	1.31

Source: Developed from information in Reference 17.

The Rubber Manufacturers Association (RMA) has examined 7 general cord treatment units for VOC emissions (not speciated for HAPs, though a similar process for tire cord treatment emits VOCs including the HAPs phenol, formaldehyde, methanol, and styrene). Uncontrolled VOC emissions from cord treatment facilities are estimated at 1,735 tpy (from solvent-use areas) and 75 tpy (from water-based coating areas). These estimates are based on the Title V definition of "potential to emit" (PTE), using 8,760 hours of annual operation. Actual solvent emissions are closer to 338 tpy (from solvent-use areas) and 40 tpy (from water-based coating areas).<sup>205</sup> Similarly, RMA estimates potential VOC emissions from 2 dip spreaders and 1 dough spreader to range from 192 tpy to 3,500 tpy.<sup>206</sup> Based on TRI information, fabric flocking is not believed to be a HAP emission source.

Of the nine or so thread manufacturing facilities that reported releases in the 1995 Toxics Release Inventory, methanol was by far the most common pollutant reported. Methanol is the organic solvent contained in coatings used for thread bonding (coating) nylon threads. Methanol emissions were high across the board and in one case, was as high as 745 TPY. Other emissions reported in high quantities include dichloromethane (highest release - 325 TPY), formaldehyde (highest release - 56 TPY), and toluene (highest release - 18 TPY).

**Control Options:** The ATMI survey shows that most facilities, both those doing water-based and solvent-based coating, are not using any controls. The types of controls that are being used include wet ESPs, fabric filters, demisters, thermal oxidizers (with and without heat recovery), catalytic oxidizers, and carbon adsorption units.<sup>207</sup> According to the RMA, wet scrubbers are also used by some cord treatment facilities, though wet scrubbers produce water pollution problems, rather than air pollution problems.<sup>208</sup> Similarly, some facilities cover the mix preparation equipment and vent VOC emissions to control devices. Emission capture systems (local ventilation systems and partial or total enclosures) are used to capture fugitive VOC emissions from coating application/flashoff areas for venting to control devices.<sup>209</sup> Since a number of the VOC emitted from polymeric coating are also HAP (e.g., toluene, MEK, xylene, and methanol), the emission reduction (90 percent) required for the VOC by the polymeric coating of supporting substrates NSPS (40 CFR part 60, subpart VVV) has been demonstrated for HAP. The best controlled facilities are believed to be those subject to NSPS. For example, the RMA reports that several cord treaters that were built before the NSPS applied (prior to 1989) are using emission controls to achieve emission reductions in the range of 85 to 90 percent.<sup>210</sup>

Many States have specified VOC content in coatings - coaters also have the option to use control equipment such as incinerators, although the former method is probably more common. The main P2 option that is currently being utilized in the industry is to reduce VOC content in coatings, or use of compliant coatings. Water-based systems are being used in place of solvent-based systems, where possible. For the water-based coatings used in cord treatment, the VOC content is typically between 4 and 8 percent of the volatile fraction to comply with the NSPS.<sup>211</sup> Another emerging technology that eliminates or reduces solvent use is powder coating.

#### **II.5.1.2.8 Backcoating (Potential HAP source).**

After a carpet has been dyed and dried, it is typically sent to the finishing department where latex and secondary backing are applied, <sup>212</sup> as shown in Figure II.5-9. The typical components of the carpet are the face yarn, below which are the primary backing and the secondary backing, separated by a layer of adhesive (CaCO<sub>3</sub>/Latex). Secondary backings are reinforcing fabrics laminated to the back of carpets to enhance dimensional stability, strength, stretch resistance, etc. Secondary backings are typically woven polypropylene (90 percent of market), jute, or attached cushion material. <sup>213</sup> The primary backing (usually polypropylene) is different from secondary backing, and is a component of tufted carpet consisting of woven and nonwoven fabric into which pile yarn tufts are inserted. Latex, a compound consisting of natural or synthetic rubber (typically, SBR), is used to coat the back of carpets and rugs to lock individual fibers and tufts in place. <sup>214</sup> Carpet latex laminating compounds and foams contain large amounts of fillers - a common one is powdered calcium carbonate. <sup>215</sup>

The carpet is steamed prior to application of chemicals, which allows chemicals to adhere to carpet and backing more easily. A coating may be applied to the carpet primary backing and a coating to the secondary backing material, after which these are fused, cured, and cooled. <sup>216</sup> There are some carpets that are merely latex coated, with no secondary backing attached. <sup>217</sup>

In applying the latex mix, the carpet is usually coated using a roller, the bottom side of which rotates in a liquid latex mix. This is followed by a doctor blade which spreads the latex and forces it to the base of the tufts in the primary backing. An application rate of 22 - 28 ounces of latex per square yard is typical. The latex acts as an adhesive for the pile yarns as well as for the secondary backing. After the secondary backing is positioned onto the carpet, the materials are pressed together by a marriage roller. This laminate then passes through a long oven (usually 80 - 160 feet long), where it is dried at temperatures of 250-300°F for 2 to 5 minutes. A Georgia Tech study <sup>218</sup> estimates that oven temperatures peak at 400°F and carpet temperatures peak at 260°F. <sup>219</sup> In this study, which was done at two carpet coating mills, latex application rates were observed to be about 0.5 lb (styrene/butadiene with ammonia for pH control and calcium carbonate filler) latex per pound of carpet, with the line having a maximum speed of 200 ft/min.

**HAP emissions:** Methanol emissions can result from its use as a latex thickener. ATMI survey results did not have a separate category for backcoating - results for backcoating operations would probably be included in the solvent / non-solvent coating operations categories.

In an ongoing project for air emission assessments for carpet manufacturing processes, Georgia Tech researchers have analyzed direct stack measurements under normal operating conditions for different process steps, including latex backcoating of carpets. <sup>220</sup> About 200 samples and 11 stack flow measurements were taken at two carpet coating facilities to measure VOCs, aldehydes and ketones, ammonia, and dissolved gas emissions. Potential to emit for HAPs (total) from the backcoating process was estimated at 4 TPY based on a nominal production rate of 16,000 yd<sup>2</sup>/hr. The HAPs detected include glycol ethers, formaldehyde, benzene, styrene, as well as others in small quantities. The latex used was a styrene/butadiene latex with calcium carbonate filler, also including various thickeners, foaming agents, and fungicides.

**Control options:** Methanol content in thickener is being reduced or eliminated by suppliers. The industry is shifting to 2 different latex backings. One has no methanol, but contains from 5 to 6

percent of ethanol, resulting in an increase in VOC emissions. The second has 0.5 percent methanol, resulting in decreased HAP and VOC emissions.<sup>221</sup>

### **II.5.1.3 Other Operations**

#### **II.5.1.3.1 Spot cleaning (Potential HAP source).**

Various facilities reported<sup>222</sup> emissions from spot cleaning operations of greater quantities than 1 TPY for HAPs such as dichloromethane, methyl chloroform, tetrachloroethylene, and trichloroethane. However, emission quantities varied widely. According to ATMI,<sup>223</sup> better quality control can significantly reduce use of spot cleaners and associated HAP emissions. At least three facilities reported that the operation was being phased out and one facility reported that they were investigating alternatives to the spot cleaners currently in use. Most facilities are not using any kind of controls with spot cleaning operations although at least three facilities reported using an unidentified air emissions control device.

#### **II.5.1.3.2 Other Operations (Potential HAP source).**

ATMI survey respondents<sup>224</sup> included various different operations in the 'other' processes category including operations such as polymerization, chemical mixing, singeing, thermal slitting, tile cutting, industrial winding, packaging, other screen printing, cut/sew, fabrication, component silos, wastewater pretreatment, parts cleaning, extruders, ink product labeling, hot melt glueing of carpet, resin manufacturing, fiber reclamation, sanforizing, and wax coatings. Most of these operations are uncontrolled, but various types of air emission controls were also reported in this category including thermal oxidizers, scrubbers, cyclones, fabric filters, wet ESPs, and others. The types of operations with HAP emissions greater than 1 TPY include processing post-consumer PET bottles into polyester staple fiber (chlorine emissions), resin manufacturing (85 TPY of formaldehyde, 41 TPY methanol - would probably not fall under the textile MACT), and some other operations resulting in some hydrochloric acid emissions (specific operations could not be identified through the survey).

The ATMI survey had no respondents for flame laminating, other laminating, thermal non-woven fabric manufacturing operations, and relatively poor responses from facilities doing solvent-based printing. Only one facility falling in SIC 3069 (fabricated rubber products) responded and responses also were poor in some other SIC codes such as narrow fabric mills, hosiery, and cordage and twine.

#### **II.5.1.3.3 Apparel and Other Finished Products Manufacture.**

The final step in textile production is when the finished fabric is converted into various apparel, household, and industrial products in cut and sew manufacturing operations. Many simpler products like sheets and bags, are produced by textile mills themselves. These operations are not likely to be major HAP emission sources.



## II.6 REFERENCES

1. Memorandum and 5 Attachments from Sharma, A. and S. York, RTI, to P. Almodóvar, EPA/OAQPS/ESD/CCPG. August 8, 1997 Final. Summary of Initial PMACT Meeting for Fabric Printing, Coating, and Dyeing.
2. Executive Office of the President, Office of Management and Budget. Standard Industrial Classification Manual. 1987.
3. Textiles. US Industrial Outlook 1993-Textiles; pp 9-1 - 9-9.
4. Reference 1.
5. Reference 1.
6. U.S. Department of Commerce. Economics and Statistics Administration. Bureau of the Census. 1992 Census of Manufacturers Data downloaded from the Internet.
7. Carpet & Rugs. The Hoover Company. North Canton, OH. 1996.
8. Reference 1.
9. Reference 7.
10. Reference 7.
11. Reference 1.
12. Polymeric Coating of Supporting Substrates - Background Information for Proposed Standards. Draft Document. April 1987. EPA-450/3-85-022a.
13. Reference 12.
14. North Carolina State University College of Textiles. Department of Extension and Applied Research. Short Course Office. Fundamental Series - Basic Textiles, short course materials.
15. USEPA. Environmental Pollution Control - Textile Processing Industry. USEPA, Environmental Research Information Center. October, 1978. EPA-625/7-78-002.
16. Reference 1.
17. Memorandum and Attachment from York, S. and A. Sharma, RTI, to P. Almodóvar, EPA/OAQPS/ESD/CCPG. October 31, 1997 Draft. Summary of meeting at which ATMI presented the results of the ATMI MACT Survey to EPA.
18. Reference 1.

19. Reference 15
20. Best Management Practices for Pollution Prevention in the Textile Industry. USEPA Office of Research and Development. Washington, DC. EPA/625/R-96/004. September 1996.
21. Reference 14.
22. Reference 20.
23. Reference 14.
24. Reference 20
25. Reference 20.
26. Dictionary of Fiber and Textile Technology. Hoechst & Celanese. 1990.
27. Reference 14.
28. Reference 12.
29. Reference 1.
30. Reference 14.
31. Reference 1.
32. Initial Assessment of Emissions from Heat Setting Carpet Yarn. United States Environmental Protection Agency. Control Technology Center. Research Triangle Park, NC. EPA-600/R-93-161. August 1993.
33. Reference 32.
34. Reference 32.
35. Reference 32.
36. Reference 17.
37. Air Emission Assessment at a Textile Finishing Plant. Jim Mulholland. FY95-96. CCACTI Project Summary. Georgia Institute of Technology.
38. Volatile Organic Compound Emissions Characterization. World Carpets, Inc. Received by York, S., RTI from Shahbazaz, M., Georgia Department of Natural Resources. July 1997.
39. Reference 32

40. Reference 32
41. Reference 17
42. Reference 32
43. Reference 14
44. Reference 32
45. Reference 17
46. Reference 1
47. Reference 1
48. Reference 20
49. Reference 14
50. Reference 14
51. Reference 20
52. Reference 20
53. Memorandum from York, S., A. Sharma, and M. Malkin, RTI to Almodóvar, EPA/OAQPS. October 28, 1997. Report of Site Visit to BGF Industries, Inc., Altavista, VA.
54. Reference 14
55. Reference 53.
56. Reference 17
57. Reference 14.
58. Reference 20.
59. Reference 15.
60. Reference 20.
61. Reference 14.
62. Reference 14.

63. Reference 7.
64. Reference 20.
65. Reference 7.
66. Reference 14.
67. Reference 14.
68. "Summary of Textile Manufacturing Operations". Submitted to the USEPA by the American Textile Manufacturers Institute. Prepared by the Institute of Textile Technology. July 1991.
69. The Nonwoven Fabrics Handbook. Association of the Nonwoven Fabrics Industry (INDA). Cary, North Carolina. 1992.
70. Reference 14.
71. Reference 68.
72. Reference 69.
73. Reference 69.
74. Reference 69.
75. Reference 53.
76. Reference 69.
77. Reference 69.
78. Reference 69.
79. Reference 69.
80. Reference 1.
81. Reference 68.
82. Reference 17.
83. Reference 15.
84. Reference 14.

85. Reference 20.
86. Reference 20.
87. Reference 1.
88. Reference 68.
89. Reference 14.
90. Memorandum from York, S., RTI to Almodovar, P., EPA/OAQPS/ESD/CCPG. December 8, 1997. Report of Site Visit - Mount Vernon Mills, Inc., Trion Operations, Trion, Georgia.
91. Reference 53.
92. Reference 20
93. Reference 14
94. Reference 17
95. Reference 90
96. Reference 68
97. Reference 90
98. Reference 90
99. Reference 1
100. Reference 14
101. Reference 68
102. Reference 1
103. Reference 14
104. Reference 68
105. Reference 90
106. Reference 1
107. Reference 90

108. Reference 17
109. Reference 20
110. Reference 37
111. Reference 17
112. Reference 20
113. Reference 14
114. Reference 68
115. Reference 20
116. Reference 1
117. Reference 14
118. Reference 20
119. Reference 20
120. Reference 14
121. Reference 90
122. Reference 1
123. Reference 14
124. Reference 68
125. Reference 20
126. Reference 1
127. Reference 14
128. Reference 68
129. Reference 90
130. Reference 14
131. Reference 1

132. Reference 1
133. Reference 90
134. Reference 90
135. Reference 20
136. Reference 20
137. Reference 20
138. Reference 17
139. Reference 90
140. Memorandum and 4 Attachments from Malkin M. and S. York, RTI, to P. Almodóvar, EPA/OAQPS/ESD/CCPG. December 15, 1997 Final. Summary of Second PMACT Meeting for Fabric Printing, Coating, and Dyeing.
141. Reference 90
142. Reference 37
143. Reference 17
144. Reference 1
145. Reference 7
146. Reference 7
147. Air Emission Factor Development for Textile Finishing and Carpet Dyeing and Coating. Mulholland et al. FY 1997 CCACTI Project Update. Georgia Institute of Technology.
148. Memorandum and 4 Attachments from York, S., and A. Sharma, RTI, to P. Almodóvar, EPA/OAQPS/ESD/CCPG. June 4, 1998 Final. Summary of meeting with Georgia Institute of Technology researchers conducting air emission factor development for carpet and coating.
149. Reference 1
150. Reference 147
151. Reference 148

152. Reference 1
153. Reference 20
154. Reference 14
155. Reference 1
156. Reference 20
157. Reference 17
158. Reference 17
159. Reference 140
160. Reference 20
161. Memorandum and Attachment from York, S., RTI, to P. Almodóvar, EPA/OAQPS/ESD/CCPG. February 3, 1998 Final. Summary of Initial Regulatory Subgroup PMACT Meeting for Fabric Printing, Coating, and Dyeing.
162. Reference 20
163. Reference 14
164. Reference 17
165. Reference 68
166. Reference 53
167. Reference 20
168. Reference 1
169. Reference 140
170. Reference 90
171. Reference 90
172. Reference 53
173. Reference 17
174. Reference 90



175. Reference 20
176. Reference 17
177. Reference 37
178. Reference 90
179. Reference 53
180. Reference 17
181. Reference 140
182. Reference 17
183. Reference 20
184. Reference 68
185. Memorandum and 4 Attachments from Malkin, M., A. Sharma, and S. York, RTI, to P. Almodóvar, EPA/OAQPS/ESD/CCPG. June 5, 1998 Draft. Summary of Third PMACT Meeting for Fabric Printing, Coating, and Dyeing.
186. Reference 1
187. Reference 12
188. Reference 12
189. Reference 1
190. Reference 12
191. Reference 12
192. Reference 12
193. Reference 1
194. Reference 20
195. Reference 1
196. Reference 12

197. Reference 12
198. Reference 12
199. Memorandum from Bhatia, K., L. Sutton, and D. L. Jones, EC/R Incorporated to Koman, T., EPA/OAQPS/CCPG. February 24, 1998. Summary of meeting of January 22, 1998 with Representatives of the Rubber Manufacturers Association.
200. Reference 199
201. Information downloaded from American Flocking Association website.
202. Reference 12
203. Reference 12
204. Reference 17
205. Reference 199
206. Reference 199
207. Reference 17
208. Reference 199
209. Reference 12
210. Reference 199
211. Reference 199
212. Reference 1
213. Reference 1
214. Reference 1
215. Reference 1
216. Reference 148
217. Reference 1
218. Reference 147
219. Reference 147

- 220. Reference 147
- 221. Reference 161
- 222. Reference 17
- 223. Reference 140
- 224. Reference 17

**APPENDIX A**

**PARTICIPANTS IN FABRIC PRINTING, COATING,  
AND DYEING STAKEHOLDER PROCESS**

**AMERICAN TEXTILE MANUFACTURERS INSTITUTE (ATMI) PARTICIPANTS**

<b>NAME</b>	<b>COMPANY</b>
Paul D'Andries	Thomaston Mills
Mike Antonowicz	Burlington Industries
Ron Beegle	Mount Vernon Mills, Inc.
David Dunn	ERM-Southeast, Inc.
John Eapen	American and Efrid (A & E)
Julie Fleming	American Textile Manufacturers Institute
J. D. (Chip) Moore	Collins & Aikman Products Co.
Mary Beth Parker	American Textile Manufacturers Institute
Robert Parsons	Russell Corp.
Gene Roberts	West Point Stevens
Roger Settlemyer	Fieldcrest Cannon
Jeff Silliman	Milliken & Co.
Greg Slominski	BGF Industries, Inc.
Jimmy Summers	Guildford Mills, Inc.
Ben Williams	Milliken & Co.

**CARPET AND RUG INSTITUTE (CRI) PARTICIPANTS**

<b>NAME</b>	<b>COMPANY</b>
Brad Britton	The Carpet and Rug Institute
Ken Fontaine	Beauliu of America
Michelle Shlapak	Mohawk Industries
Carroll Turner	The Carpet and Rug Institute
Troy Virgo	Shaw Industries, Inc.
Eddie Whorton	Shaw Industries, Inc.

**OTHER INDUSTRY AND TRADE ASSOCIATION PARTICIPANTS**

NAME	COMPANY
<b>Chuck Brooks</b>	<b>National Association of Hosiery Manufacturers</b>
<b>Henry Boyter</b>	<b>Earth Tech-Charlottesville</b>
<b>Barbara Burdick</b>	<b>Kenyon Industries</b>
<b>Steve Byrne</b>	<b>Sytec</b>
<b>Arthur Capper</b>	<b>NCDEHNR</b>
<b>Sam Calouche</b>	<b>Firestone</b>
<b>David DeWulf</b>	<b>INDA</b>
<b>Ray DiMascio</b>	<b>The Goodyear Tire &amp; Rubber Co.</b>
<b>Tom Flynn</b>	<b>Allied Signal</b>
<b>John Glidden</b>	<b>L. W. Packard &amp; Co., Inc.</b>
<b>Donald Greene</b>	<b>Cranston Print Works Company</b>
<b>C. Tucker Helms</b>	<b>ETAD</b>
<b>Mike Heth</b>	<b>Allied Signal</b>
<b>Lewis Johnson</b>	<b>American Yarn Spinners Association</b>
<b>Ernie Karger</b>	<b>The Gates Rubber Company</b>
<b>Alva King</b>	<b>Bridgestone/Firestone, Inc.</b>
<b>Peter Mayberry</b>	<b>INDA</b>
<b>Mike McNally</b>	<b>General Tire</b>
<b>Gary Moore</b>	<b>Institute of Textile Technology</b>
<b>Gail Murphree</b>	<b>United Technologies</b>
<b>Carol Nieme</b>	<b>CMA's Solvents Council</b>

**OTHER INDUSTRY AND TRADE ASSOCIATIONS  
PARTICIPANTS (continued)**

<b>Tracey Norberg</b>	<b>Rubber Manufacturers Association</b>
<b>Michael Oberlander</b>	<b>Carleton Woolen Mills</b>
<b>Fred Parry</b>	<b>DyStar L.P.</b>
<b>Jim Pruitt</b>	<b>John Boyle and Co., Inc.</b>
<b>Sandra Perry</b>	<b>East Coast Environmental</b>
<b>Lamont Powell</b>	<b>Clairant Corporation</b>
<b>Mark Raumikaitis</b>	<b>Synthon Industries</b>
<b>Mark Richardson</b>	<b>The Freudenberg Nonwovens Group</b>
<b>Dr. Alexander Ross</b>	<b>RADTECH</b>
<b>Marcia Rounsaville</b>	<b>Industrial Fabrics Association International</b>
<b>Eleanor Sun</b>	<b>PGI Nonwovens</b>
<b>Tommy Thompson</b>	<b>Sarah Lee Hosiery</b>
<b>Marty Tremby</b>	<b>The Goodyear Tire &amp; Rubber Co.</b>
<b>David Trumbull</b>	<b>Northern Textile Association</b>
<b>Tom Wood</b>	<b>Cooper Tire &amp; Rubber Co.</b>
<b>Charles Yang</b>	<b>The University of Georgia</b>

**REGULATORY SUBGROUP PARTICIPANTS**

<b>Barry Addertion</b>	<b>NCDEHNR</b>
<b>Paul Almodovar</b>	<b>EPA/OAQPS/ESD/CCPG</b>
<b>Ken Babb</b>	<b>NCDEHNR</b>
<b>Belinda Breindenbach</b>	<b>EPA/OECA</b>
<b>John Burke</b>	<b>NCDEPPEA</b>
<b>Phil Davis</b>	<b>Alabama DEM</b>
<b>Lisa Edwards</b>	<b>NCDEHNR</b>
<b>Joe Eller</b>	<b>South Carolina DHEC</b>
<b>Rob Fisher</b>	<b>NCDEHNR</b>
<b>Danielle Fuligni</b>	<b>EPA/OPPTS</b>
<b>Ernie Fuller</b>	<b>NCDEHNR</b>
<b>Linda Herring</b>	<b>EPA/OAQPS/ESD/CCPG</b>
<b>Jimmy Johnston</b>	<b>Georgia DNR</b>
<b>Mike Landis</b>	<b>NCDEHNR</b>
<b>Peter Lloyd</b>	<b>NCDEHNR</b>
<b>Melissa Malkin</b>	<b>Research Triangle Institute</b>
<b>Carlos Nunex</b>	<b>US EPA/ORD</b>
<b>Steve Maynard</b>	<b>NCDEHNR</b>
<b>Kim Melvin</b>	<b>NCDEHNR</b>
<b>Steve Maynard</b>	<b>NCDEHNR</b>
<b>Kim Melvin</b>	<b>NCDEHNR</b>
<b>Venkata Panchakarla</b>	<b>Florida DEP</b>



**REGULATORY SUBGROUP PARTICIPANTS (continued)**

<b>Mona Pedersen</b>	<b>Virginia DEQ</b>
<b>Eric Sanderson</b>	<b>Alabama DEM</b>
<b>Marzieh Shahbazaz</b>	<b>Georgia DNR</b>
<b>Aarti Sharma</b>	<b>Research Triangle Institute</b>
<b>Stephanie Shealy</b>	<b>SC DHEC</b>
<b>Dave Skelly</b>	<b>Virginia DEQ</b>
<b>Jim Southerland</b>	<b>NC DEHNR</b>
<b>Steve York</b>	<b>Research Triangle Institute</b>
<b>John Yntema</b>	<b>Georgia DNR</b>
<b>Robert Zerbonia</b>	<b>Research Triangle Institute</b>

## APPENDIX B

### DEFINITIONS

Following are definitions of some of the important elements and operations that make up the Fabric Printing, Coating, and Dyeing source category for the purposes of this document:

**Backcoating** - Backcoatings are adhesive substances (such as types of latex) that serve to cement tufts and fibers to primary backings and may also serve to laminate a secondary backing to the primary backing. The secondary backing materials provide dimensional stability and enhanced performance of the final carpet product.

**Binder** - An adhesive applied with a solvent, or a softenable plastic melted to bond fibers together in a web or to bind one web to another.

**Bleaching**<sup>a</sup> - Any of several processes to remove the natural and artificial impurities in fabrics to obtain clear whites for finished fabric or in preparation for dyeing and finishing.

**Carpet dye/finish application unit** - Any continuous dyeing or finishing range including dye/finish (backcoating or other finish) application station(s), flashoff area(s), and drying oven(s) located between a substrate input station and a rewind or output station. This includes, for instance, a unit that dyes a continuous web of carpet. For a batch process, e.g., beck dyeing, the dye/finish application unit includes the dye application station and associated drying and any other finish application station(s) included in the drying range. More than one type of operation (such as dyeing and other finish application) may be included within a dye/finish application unit.

**Coating** - A protective, decorative, or functional film applied as a thin layer to a textile substrate and which cures to form a continuous solid film.

**Coating applicator** - Any apparatus used to apply a coating to a continuous substrate.

**Coating mix preparation equipment** - All mixing vessels in which solvent and other materials are blended to prepare polymeric coating.

**Coating operation** - Any coating applicator(s), flashoff area(s), and drying oven(s) located between a substrate unwind station and a rewind station that coats a continuous web to produce a substrate with a polymeric coating. Should the coating process not employ a rewind station, the end of the coating operation is after the last drying oven in the process.

**Colorfastness**<sup>a</sup> - Resistance to fading; i.e., the property of a dye to retain its color when dyed (or printed) textile material is exposed to conditions or agents such as light, perspiration, atmospheric gases, or washing that can remove or destroy the color. A dye may be reasonably fast to one agent and only moderately fast to another. Degree of fastness to color is tested by standard procedures. Textile materials often must meet certain fastness specifications for a particular use.

**Drying cylinders**<sup>a</sup> (**cans**) - Any of a number of revolving cylinders for drying fabric or yarn. They are arranged either vertically or horizontally in sets, and the number varying according to the

material to be dried. They are often internally heated with steam and Teflon-coated to prevent sticking.

**Drying oven** - A chamber within which heat is used to dry a surface coating; drying may be the only process or one of multiple processes performed in the chamber.

**Dyeing**<sup>a</sup> - A process of coloring fibers, yarns or fabrics with either natural or synthetic dyes.

**Dye range**<sup>a</sup> - A broad term referring to the collection of dye and chemical baths, drying equipment, etc., in a continuous-dyeing line.

**Fiber-suspension solvent** - Solvent used in solvent bonding of nonwovens, which can be used for a few solvent susceptible fibers, to partly dissolve their surfaces and thereby create an adhesive of themselves. Removing the solvent causes resolidification of the fiber surface and bonding at crossover points.

**Finishing** - Finishing encompasses any of several mechanical (e.g., texturizing, napping) and chemical processes (e.g., optical finishes, softeners, urea-formaldehyde resins for crease resistance) performed on fiber, yarn, or fabric to improve its appearance, texture, or performance.

**Flashoff area** - The portion of a coating operation between the coating applicator and the drying oven where VOC begins to evaporate from the coated substrate.

**Flocking** - A method of cloth ornamentation in which adhesive is printed or coated on a fabric, and finely chopped fibers are applied all over by means of dusting, air-blasting, or electrostatic attraction.

**Heat-setting**<sup>a</sup> (**greige**) - The process of conferring dimensional stability and often other desirable properties such as wrinkle resistance and improved heat resistance to manufactured fibers, yarns and fabrics by means of either moist or dry heat.

**Lamination** - Laminated fabric is composed of a high-strength reinforcing scrim or base fabric between two plies of flexible thermoplastic film. Usually open scrims are used to permit the polymer to flow through the interstices and bond during calendaring. Also, two or more fabrics or a fabric and a paper substrate may be bonded with an adhesive to form a laminate.

**Liquid Binder** - Nonwoven binding agent in water-borne or solvent-borne solutions or emulsions.

**Mercerization**<sup>a</sup> - A treatment of cotton yarn or fabric to increase its luster and affinity for dyes. The material is immersed under tension in a cold sodium hydroxide (caustic soda) solution in warp or skein form or in the piece, and is later neutralized in acid. The process causes a permanent swelling of the fiber and thus increases its luster.

**Polymeric coating of supporting substrates** - A web coating process that applies elastomers, polymers, or prepolymers to a supporting web other than paper, plastic film, metallic foil, or metal coil.

**Printing** - Color and patterns, usually in the form of a paste, are applied to fabrics using a variety of techniques of which rotary screen printing is the most commonly used, with pigments being the most common dye class used. Fabric is treated with steam, heat, or chemicals to fix the color.

**Scouring**<sup>a</sup> - An operation to remove the sizing and tint used on the warp yarn in weaving and, in general, to clean the fabric prior to dyeing.

**Skein**<sup>a</sup> - A continuous strand of yarn or cord in the form of a collapsed coil. It may be any specified length and is usually obtained by winding a definite number of turns on a reel under prescribed conditions. The circumference of the reel on which yarn is wound is usually 45 to 60 inches.

**Slashing** - Slashing or sizing is the application of a chemical sizing solution to warp yarns prior to weaving to protect against snagging or abrasion that could occur during weaving. Sizing is done on a large range called a slasher using pad/dry techniques and the yarns are dried over hot cans or in an oven.

**Solvent-borne** - Coatings in which volatile organic compounds are the major solvent or dispersant.

**Substrate** - The surface to which a coating is applied.

**Tenter frame**<sup>a</sup> - A machine that dries fabric to a specified width under tension. The machine consists essentially of a pair of endless chains on horizontal tracks. The fabric is held firmly at the edges by pins or clips on the two chains that diverge as they advance through the heated chamber, adjusting the fabric to the desired width.

**Thermoplastic** - Resin capable of being repeatedly softened by heat and hardened by cooling. These materials, when heated, undergo a substantially physical rather than chemical change. Thermoplastic resins can be completely dissolved with appropriate solvents.

**Thermoset** - Resin that, when cured by application of heat or chemical means, changes into a substantially infusible and insoluble material. Thermosetting resins will soften but will not dissolve in any solvents.

**Thermoplastic Fiber** - Nonwoven binding agent in the form of a thermoplastic fiber.

**Thermoplastic or thermosetting powder** - Nonwoven binding agent in the form of a dry powder.

**Waterborne coatings** - Coatings in which water accounts for more than 5 weight percent of the volatile portion.

**Web Coating** - The coating of products, such as fabric, paper, plastic film, metallic foil, metal coil, cord, and yarn, that are flexible enough to be unrolled from a large roll; and coated as a continuous

---

<sup>a</sup> The source of this definition is the *Dictionary of Fiber and Textile Technology*, published by Hoechst Celanese Corporation in 1990.

substrate by methods including, but not limited to, knife coating, roll coating, dip coating, impregnation, rotogravure, and extrusion.

**Yarn/Spin Finish** - Spin finishes are compounds, typically applied by fiber manufacturers to synthetics, just after the fiber exits the spinnerette in the extrusion process. These are typically applied as lubricants or to suppress static electricity for the yarn as it goes through high-speed winding equipment. Other waxes and oils (not spin finishes) may be introduced at later stages.