

SECTION 11 PLUMBING AND CROSS CONNECTION CONTROL DRAINS

INDEX

I.	Plumbing Systems	11 - 1
II.	Cross-Connections: Direct & Indirect	11 - 1
III.	Forces Acting on Cross-Connections, Backflow: Backpressure & Back-Siphonage.	11 - 4 11 - 4
IV.	Evaluating Cross-Connections: High & Low Hazard, Continuous & Noncontinuous Pressure	11 - 6 11 - 6
V.	Physical Backflow Prevention Methods: Air Gap & Barometric Loop.	11 - 7
VI.	Mechanical Backflow Assemblies & Devices	11 - 9
	Hose Bibb Vacuum Breaker	11 - 10
	Atmospheric Vacuum Breaker	11 - 11
	Pressure Vacuum Breaker	11 - 12
	Backflow Preventer with an Intermediate Atmospheric Vent	11 - 15
	Reduced Pressure Zone Backflow Prevention Assembly	11 - 20
	Double Check Valves	11 - 21
VII.	Typical Retail Food Service Cross-Connections.	11 - 22
VIII.	Air Gaps & Air Breaks for Drains & Waste	11 - 26
IX.	References & Resources	11 - 28

I. PLUMBING SYSTEMS

Once a potable water system (also referred to as "safe drinking water" or just "drinking water") has been contaminated by the inadvertent actions of the user or installer, the foreign or toxic material can be distributed throughout the facility's potable plumbing system and adjacent premises on the same supply. The contaminated water, if undetected and utilized, may subsequently cause illness or death. Therefore each business, institution, residence, or other user has the ultimate responsibility to protect its potable water from any actual or potential introduction of contaminants or pollutants. The entire piping network for a water system, from the point of origin to the point of use, is divided into two categories: PRIMARY (containment) and SECONDARY (isolation) systems.

PRIMARY SYSTEM or CONTAINMENT

The primary system is composed of the water mains used by the water purveyor to deliver water to the various buildings (or service connections) on the system. The water purveyor is responsible for delivering safe drinking water to the point of delivery for the customer's or users water system (secondary system). To protect the system from foreign or toxic materials being introduced via the customer, a backflow prevention assembly or device is installed at the water service entrance for "containment" on the premises.

SECONDARY SYSTEM or ISOLATION

The secondary system is the plumbing network that distributes potable water from the down stream side of the water meter or service connection to the points of use throughout the facility and/or premises. Remember that few people are aware of what is occurring inside the building and/or premises (secondary system). The determination of cross-connections is, in part, the function of the inspector; however, it is the ultimate responsibility of the owner to comply with state and local plumbing codes specific for that jurisdiction. Safeguarding the system is met by "isolation," providing backflow protection at each actual or potential cross-connection on the premises.

II. CROSS CONNECTIONS

A cross-connection is an ACTUAL or POTENTIAL link between the potable water supply and a source of contamination (sewage, chemicals, gas, etc.). This link can be envisioned as a conduit or hose permitting the transfer of foreign material into a safe drinking water system. A cross-connection can be any temporary or permanent direct connection (hard plumbed), bypass arrangement, jumper connection, removable section, swivel or change over device, etc. that could connect a potable system to a non-potable source. Ideally, it is best not to have any cross-connections, but in certain situations they may be unavoidable. When an installation requires a cross-connection (as a last resort or unavoidable situation i.e., boiler, injector units, chemical aspirators), it must be properly protected with an acceptable backflow prevention assembly or device to eliminate any potential for a reverse flow back into the potable supply. Unprotected cross-connection threatens the health and safety of individuals and food or beverage products utilizing water from that system.

TWO TYPES OF CROSS-CONNECTIONS

1. DIRECT CONNECTION: Direct connections are a physical connection between a potable and non-potable system. An example of this would be a water supply line connected directly to a boiler, sewage line, or other nonpotable auxiliary water source. A direct pathway exists between the two separate systems for contamination to be transferred into the potable system as shown in the diagrams below. A direct connection is subject to both back-siphonage and backpressure (see next page).

Valved connection between potable water and nonpotable fluid.

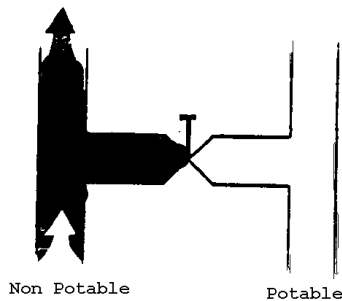

Valved connection between Potable water and sanitary sewer.

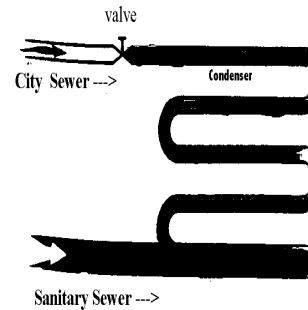

2. INDIRECT CONNECTION: An indirect connection between a potable and nonpotable supply does not exist under "normal" conditions; however, under "unique" circumstances a pathway for contamination can occur. Usually the source of contamination may back-up, be blown across, siphoned, pushed or diverted into a potable water supply. An indirect connection is only subject to backsiphonage (see next page).

Example scenario, the end of a faucet terminates below the flood level of a sink, (referred to as a "submerged inlet" because it does not provide the required air gap), and the waste backs up or the sink becomes clogged to the point that the water inlet becomes submerged. If a vacuum or negative pressure should develop in the potable supply, the contaminant could be siphoned into the water supply.

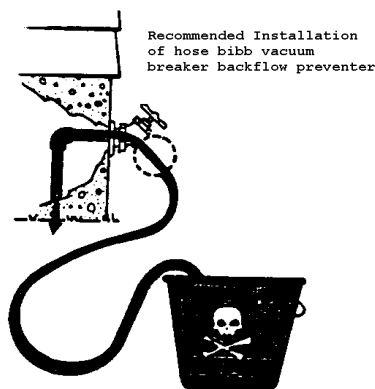

Backsiphonage in a plumbing system.

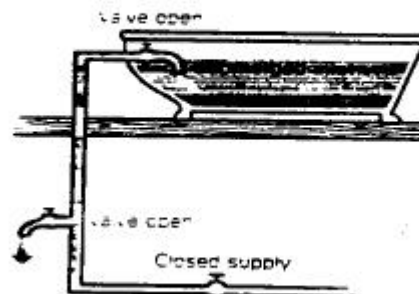

III. FORCES ACTING ON CROSS-CONNECTIONS

Some cross-connections are immediately obvious, but others can be subtle and difficult to find. Contamination or pollution occurs when the pressure differentials between the water supply and another system, via some connection, are sufficient to transfer the contaminant or pollutant into the potable supply. The temporary reversal of pressures or momentary vacuums in the water supplies can be freakish and unpredictable. These hydraulic forces can either **PUSH** (forced by higher pressure than the potable supply) or **Pull** (vacuum/siphon, the potable supply drops below normal levels) the contaminant into the drinking water system.

BACKFLOW

Backflow is a reverse flow in the primary or secondary system that is opposite to the expected or intended direction. This flow reversal is undesirable; however, a properly protected system can remain safe. There are two types of backflow, acting separately or in combination, that allow contaminants (high hazard) or pollutants (low hazard) to enter the water supply via a cross connection: BACKPRESSURE and BACK-SIPHONAGE.

BACKPRESSURE (A PUSHING FORCE) Backpressure occurs when both systems (potable & nonpotable) are under pressure (above atmospheric pressure or positive head pressure), but the nonpotable system has a greater pressure than the potable system. This pressure differential pushes the contaminant or pollutant into the potable supply. Pumps or thermal expansion from boilers connected to a supply are examples of how these pressure differentials can be created.

PRINCIPLE CAUSES OF BACKPRESSURE:

For backpressure to occur, a "direct connection" to another system **must** exist. This other system would actually or potentially be operated at a higher pressure than the potable supply, i.e., a fertilizer injector system, booster pump, boiler, fire sprinkler system or other auxiliary water source.

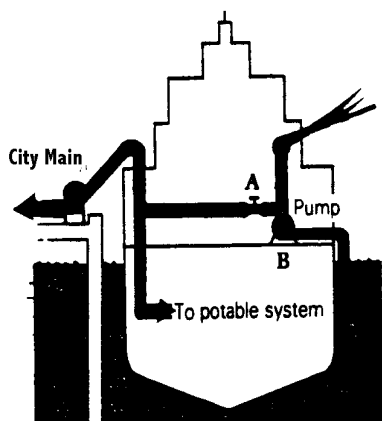

Potential Backpressure on City Supply

A. Contact Point: A valve connection exists between the potable and the nonpotable systems aboard the ship.

B. Cause of Reversed Flow: While the ship is connected to the city water supply system for the purpose of taking on water for the potable system, the valve between the potable and nonpotable systems is opened, permitting contaminated water to be pumped into the municipal supply.

BACK-SIPHONAGE (VACUUM, PULLING FORCE) Back-siphonage occurs when the pressure in the water supply drops below zero (less than atmospheric pressure or negative head pressure), and the adjacent nonpotable source is drawn or siphoned into the potable supply.

NOTE: Back-siphonage can occur with either a "direct" or "indirect" connection, or the systems and be "opened" or "closed" - meaning exposed/open to the atmosphere, or not exposed/closed to the atmosphere.

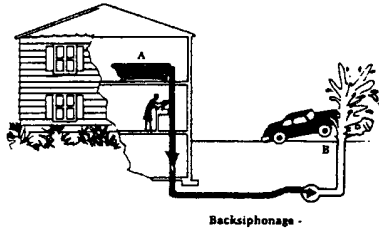

Backsiphonage -

Backsiphonage

- A. **Contact point:** There is a submerged inlet in the second floor bathtub.
- B. **Cause of Reversed Flow:** An automobile breaks a nearby fire hydrant causing a rush of water and negative pressure in the service line to the house sucking dirty water out of the bathtub.
- C. **Suggested Correction:** The hot and cold water inlets to the bathtub should be above the rim of the tub.

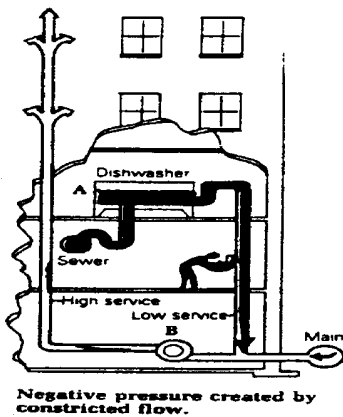

Negative pressure created by constricted flow.

Backsiphonage

- A. **Contact Point:** The water supply in the dishwasher is not protected by a vacuum breaker. Also, the dishwasher has a solid waste connection to the sewer.
- B. **Cause of Reversed Flow:** The undersized main serving the building is subject to reduced pressure and therefore only the first two floor of the building are supplied directly with city water pressure. The upper floors are served with a booster pump drawing suction directly from the water service line. During periods of low city pressure the booster pump suction creates negative pressure in the low system thereby reversing the flow.
- C. **Suggested Correction:** The dishwasher hot and cold water should be supplied through an airgap and the waste from the dishmachine should be discharged through an indirect waste line. The booster pump should be equipped with a low-pressure cutoff device.



PRINCIPLE CAUSES OF BACK-SIPHONAGE:

1. Undersized sections of pipe can create an aspirator effect in the restricted area.
2. A break or repair in a supply line can create a vacuum or siphoning effect (as gravity drains the water out) on the elevated portions of the system above the effected area.
3. A high water withdrawal, such as fire fighting or water main flushing, can create a vacuum. This withdrawal is more likely to create stronger negative pressures at the higher elevations on the system.
4. A vacuum can be induced on the suction side of a booster pump, such as high-rise buildings and processing plants.

IV. EVALUATING CROSS-CONNECTIONS

There are several different types of assemblies (units that can be tested after installation) and devices (can not be tested after installation) available for controlling cross-connections and preventing backflow. The type of assembly or device needed depends upon the type of cross connection, the intended purpose of the plumbing configuration, and what could backflow into the water supply under various scenarios.

EVALUATING EXISTING OR POTENTIAL CROSS-CONNECTIONS:

1. Evaluate the plumbing supply, equipment attached to it, and any waste lines attached or near by. Think about **WHAT COULD GO WRONG** with this design and **WHAT CAN BE DONE TO MAKE IT SAFE**.
2. Determine the **DEGREE OF HAZARD INVOLVED**, either a **HIGH** or **LOW** hazard will exist with a cross-connection. The degree of hazard depends on whether the nonpotable source is deleterious or not.

HIGH HAZARD situations exist when there is an actual or potential connection for any toxic or infectious substance (also referred to as a **CONTAMINATION**), to be introduced into the water supply, and may create a danger to the health and well-being of anyone using the water. Examples of contaminants are pesticides, chemicals, and infectious microorganisms.

LOW HAZARD situations exist when there is an actual or potential connection for a nontoxic substance (also referred to as a **POLLUTANT**) to be introduced to the water supply and create a nuisance, or be aesthetically objectionable to the water user. Examples of pollutants are turbidity, beverages, and food coloring.

3. Evaluate the use of the backflow prevention device relative to the **TIME** that supply pressure is present on both the "up stream" and "down stream" side of the device.

CONTINUOUS PRESSURE conditions exist when the water pressure remains on both sides of the device for **more than 12 hours**. Continuous water pressure can exist under **DYNAMIC** conditions (the water is "on" and flowing in the intended direction through the device) or **STATIC** conditions (the water is "on" but a shut off device down stream in the "off" or closed position results in no flow through the device).

NON-CONTINUOUS PRESSURE conditions exist when the device is only subject to intermittent water pressure on both sides of the device that does not exceed 12 hours.

Note: Continuous and non-continuous pressure conditions are important factors in determining the installation and use of backflow prevention devices.

V. PHYSICAL BACKFLOW PREVENTION METHODS

AIR GAP or **PHYSICAL AIR GAP** (an "air break" is in reference to waste lines only): An air gap is the **MOST DESIRABLE METHOD OF BACKFLOW PREVENTION**. It is simple, economical, non-mechanical (no moving parts), fail safe, and can be used for potential back-siphonage or backpressure situations. An air gap is an unobstructed, vertical air space that separates a potable system from a nonpotable system. This air gap is necessary to prevent any contaminant or pollutant from being siphoned or pushed back into the potable water supply. Although this is an extremely effective backflow preventer, the interruption in the piping creates a subsequent pressure drop on the "down stream" portion. Consequently, most air gaps are used at the end of the supply line or faucet such as at a sink, vat or storage tank.

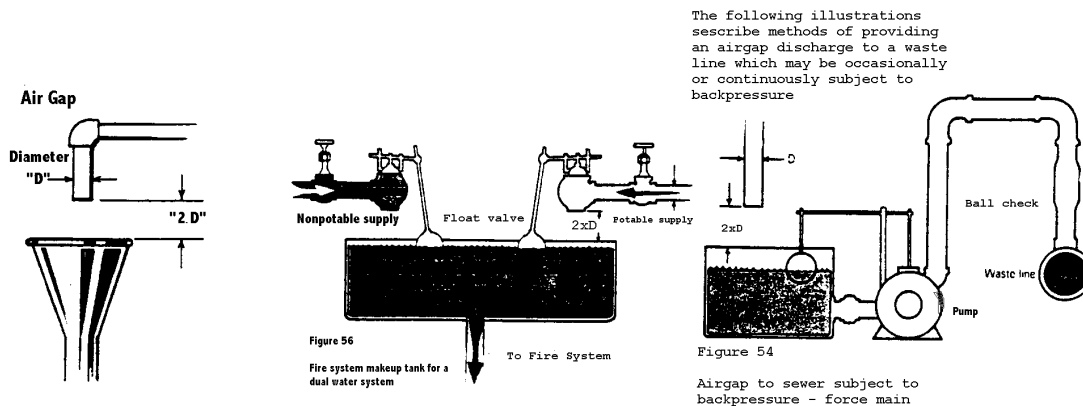

AIR GAP INSTALLATION & USE:

1. The air gap must be the greater of the two - **A MINIMUM OF ONE INCH OR TWICE THE INSIDE DIAMETER OF THE SUPPLY PIPE**. This distance is measured from the supply pipe to the flood level rim (the point of over flow) of the receptacle or fixture.
2. Air gaps require inspection for any compromised "2xD or 1 inch" requirements and any splashing problems, but no testing is necessary.
3. An air gap can be installed in a continuous piping system to protect the source from any potential contaminant on the down stream side of the system. Providing an air gap within the supply system (versus at the end of the supply line) would require a reservoir and possibly a booster pump. An open reservoir can subject the water to air borne pollutants and the loss of free chlorine in a treated supply. If a reservoir is utilized, then there needs to be a means to periodically drain and clean the tank.

BAROMETRIC LOOP

The barometric loop is an extension of the supply line that can be construed as a giant upside down "U". This configuration is designed based on the fluid dynamics of water and is utilized to protect all down stream inlets against "back-siphonage" **only**. An absolute vacuum on a pipe can only "pull" the water up 33.9 feet; to go any higher, a pump would be necessary to push the water up the column. The barometric loop must be at least 35 feet tall and the base must be at a higher elevation than any of the inlets or fixtures that are on the down stream side of the loop. The size of the 35-foot high loop limits its practicality for application (processing plant) for protecting against negative pressure.

Effect of evacuating air from a column.

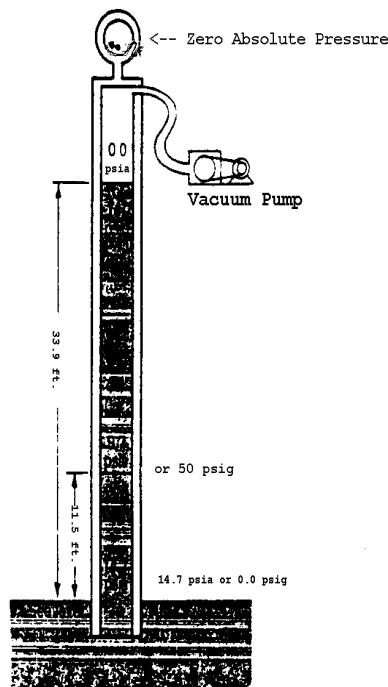

Barometric Loop

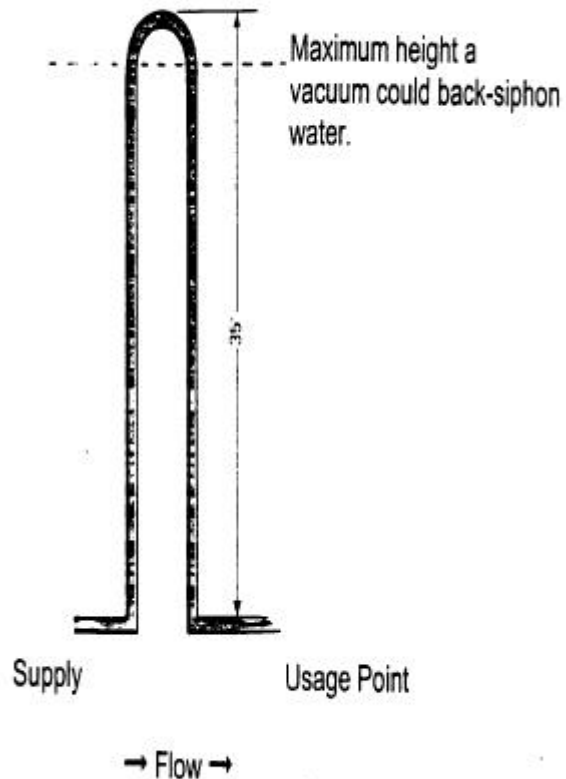

BAROMETRIC INSTALLATION & USE:

1. The loop must be at least 35 feet upright and all plumbing inlets or fixtures must be no higher than the loop's base.
2. Approved for CONTINUOUS PRESSURE & NO POTENTIAL backpressure

VI. MECHANICAL BACKFLOW ASSEMBLIES & DEVICES

The type of mechanical assembly or device selected must be appropriate for the degree of hazard and specific application relevant to the potential backflow possibilities. Mechanical backflow preventers consist of single or multiple check valves that open from the flow pressure of the potable water. These valves are fabricated to seat tightly on a machined surface and when closed, prevent any flow in the wrong direction. Also, some devices have air inlets or ports that are vented to the atmosphere to relieve any vacuum or negative pressure developed in the system. All backflow devices must be installed so they are accessible for inspection, service and repair.

NOTE:

The specific use and installation of a backflow prevention assembly or device must be clarified by the manufacturer and comply with the plumbing codes governing the jurisdiction in which the unit is installed.

AMERICAN SOCIETY OF SANITARY ENGINEERING (ASSE)

ASSE is a consensus, voluntary ANSI (American National Standards Institute) accredited association that develops and maintains product performance standards for component parts of the plumbing systems and professional qualification standards. Eighteen standards are for backflow devices/assemblies. On the following pages, examples of various devices are cited with the number for the ASSE standard under "Installation & Use."

FOOD PROCESSING & RETAIL FOOD CODE PLUMBING REGULATIONS

FDA Food Code

Chapter 5. The following section is from the Food and Drug Administration's 1997 Food Code (Food establishments) pertaining to: 5-202.14 Backflow Prevention Device, Design Standard.

A backflow or backsiphonage prevention device installed on a water supply system shall meet American Society of Sanitary Engineering (A.S.S.E.) Standards for construction, installation, maintenance, inspection, and testing for that specific application and type of device.

Grade A Pasteurized Milk Ordinance (PMO), Current Edition

Item 8r, 7p, -and Appendix -D, Standards for Water Sources.

National Shellfish Sanitation Program Manual of Operations, Part II 1995 Revision

Section D, Part 8 and 9.

HOSE BIBB VACUUM BREAKER (HBVB)

A hose bibb vacuum breaker contains one spring loaded valve and an atmospheric vent that is controlled by a diaphragm seal. The HBVB is installed on the end of a hose bibb (sill cock or boiler drain inlet) for a garden hose, slop/mop sink hose etc., or anywhere else a hose can be connected. Internally, the valve is spring loaded to be in a closed position and opens with flow in the proper direction. As the water flow begins (dynamic, water flow in the desired direction), the valve opens and allows the diaphragm seal to close off the atmospheric vent (the flow pressure is what moves & holds the diaphragm against the vent ports). When zero pressure or back-siphonage (negative pressure) conditions exist, the spring pulls the valve closed and simultaneously pushes the diaphragm (thus, opening the vent to relieve any vacuum) into position to form a tight seal between the valve and valve seat. Under static conditions (no flow) with the HBVB, the check valve may or may not be closed. (The HBVB is not approved for continuous pressure but there may be time periods when water pressure exists on both sides of the device)

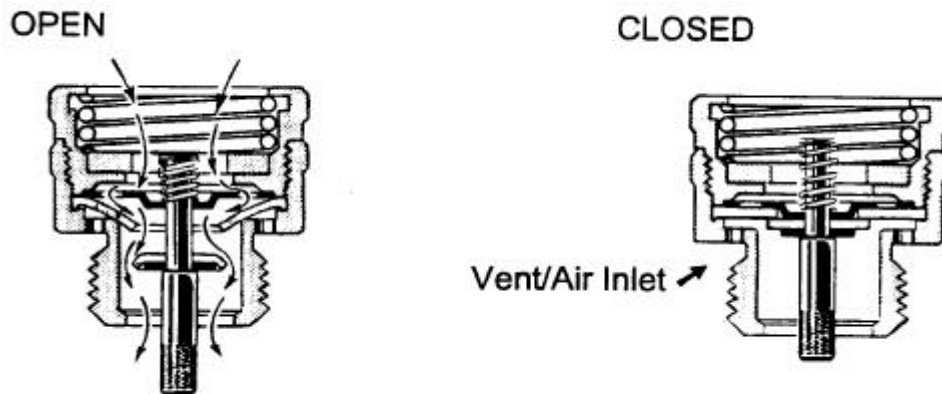

HBVB INSTALLATION & USE:

1. Shut off valves must be located up stream from the vacuum breaker, and spring-loaded pistol-grip shutoff valves are not to remain on the hose with the water left on, when not being actively used.
2. Each hose connected to a manifold or "Y" must be provided with its own HBVB, i.e., county fair, and special events where several vendors may share one hose spigot
3. Approved for **HIGH HAZARDS, NON-CONTINUOUS PRESSURE & NO POTENTIAL BACKPRESSURE** ASSE standard #1011

NOTE- HBVB's cannot be used under continuous pressure conditions (defined as water pressure on both sides of the unit for more than 12 hours), because the spring loaded valve may stick or freeze in the open position, thus making the water supply vulnerable to backflow. Remember you must evaluate the HBVB in its setting and determine the use and time. If the use period extends over 12 hours, then approved continuous pressure backflow devices must be installed.

ATMOSPHERIC VACUUM BREAKER (AVB)

This device has an internal polyethylene or metal float valve that moves up and down on a shaft (not spring loaded). Water moving in the normal direction of flow lifts the float, and causes the atmospheric vent to close (an opening on the top of the unit is open to the air). The normal water pressure keeps the float valve in the upward closed position. Shutting off the water causes the float to drop; the supply valve to close; and results in the atmospheric vent being open. With the water off, the down stream piping of the AVB is open to the atmosphere, creating an air gap, and thus preventing any back-siphonage. When a negative pressure occurs on the supply side, the float valve drops, closing off the supply, and opening the atmospheric vent. Thus, any down stream contamination will not be siphoned into the potable supply. The atmospheric vacuum breaker provides **excellent protection against "backsiphonage" only**. Exposing the AVB to backpressure can cause the atmospheric valve to modulate up and down, thus permitting a potential contaminant, via backpressure, to enter the water supply.

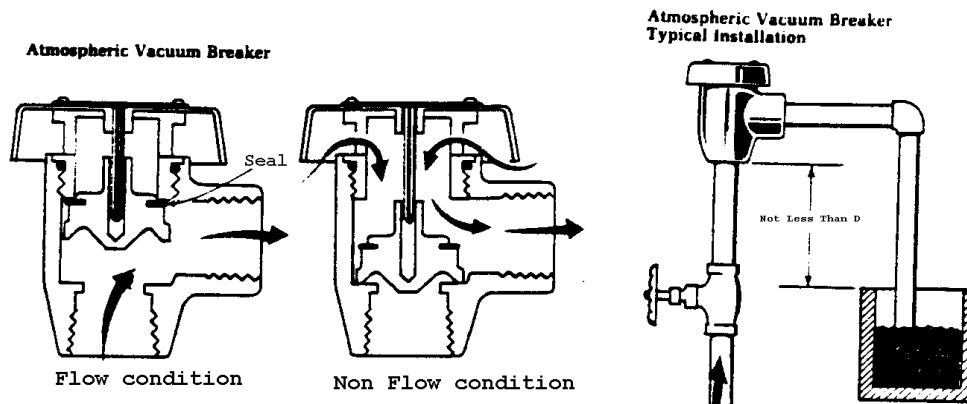

AVB INSTALLATION & USE:

1. The mushroom shaped device must be installed vertically (upright position), with the atmospheric opening at the top and the elevation of the unit must be at least 6 inches above the highest inlet, "down stream" of the AVB.
2. All shutoff devices must be located "up stream" from the AVB (supply side). This unit cannot be tested after installation.
3. Approved for **HIGH HAZARDS, NON-CONTINUOUS PRESSURE & NO POTENTIAL BACKPRESSURE.** ASSE standard #1001

NOTE: AVB's cannot be used under continuous pressure conditions (defined as water pressure on both sides of the unit for more than 12 hours), because the float valve may stick or freeze in the up position, thus making the water supply vulnerable to potential backsiphonage. Remember, you must evaluate the AVB in its setting and determine the use and time. If the use period extends over 12 hours, then an approved continuous pressure backflow device must be installed.

PRESSURE VACUUM BREAKER (PVB)

The PVB is similar to the atmospheric vacuum breaker (AVB), except that it has two test cocks and two gate valves (new units use ball valves) for testing the unit, and it also has two positive seating (spring loaded) valves. The first check valve (supply side) is spring loaded for a closed position and "guards" the potable water supply side; when the water supply is turned on, the flow pushes it in the open position. The second check valve or air inlet valve (down stream side) is spring loaded for an open position to the atmosphere and only closes when the supply water is turned on. When the supply pressure drops to or below atmospheric pressure (below 0 gauge pressure), the second check valve opens to the atmosphere and, the first check valve closes. As with the AVB, the PVB only provides protection for back-siphonage.

Pressure Vacuum Breaker

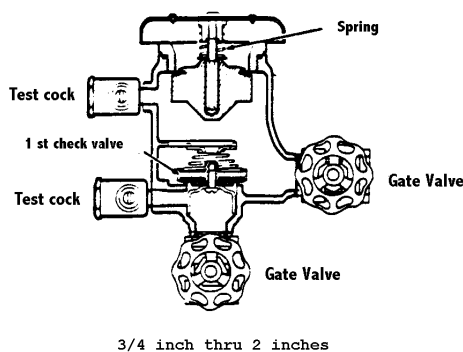

Typical Agricultural and Industrial Application of Pressure Vacuum Breaker

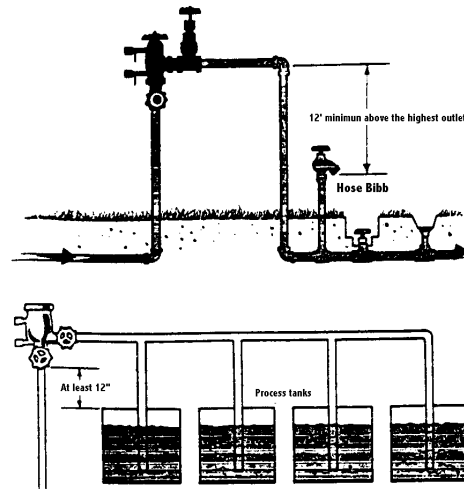

PVB INSTALLATION & USE:

1. The unit is generally used in agricultural, irrigation, and industrial applications.
2. The PVB must be installed at least 12 inches above the highest elevated inlet or fixture on its down stream side. Also, the unit must have a shut off valve on each side and two test cocks for testing.
3. The device must be located in an accessible area for testing and servicing. Also, it is permissible to install shut off devices down stream of this unit.
4. Lines should be thoroughly flushed prior to installation in order to prevent any debris from lodging in the valve seats and preventing a tight seal.
5. The PVB is approved for **HIGH HAZARD- CONTINUOUS PRESS RE & NO POTENTIAL BACKPRESSURE.** ASSE standard #1020

BACKFLOW PREVENTERS WITH INTERMEDIATE ATMOSPHERIC VENT

1. SPECIALTY UNITS FOR 1/2 & 3/4 INCH SUPPLY LINES

This device contains an atmospheric vent between two spring loaded check valves, and these valves are spring loaded for automatic closure under static (no water flow) conditions. The atmospheric vent is controlled by a diaphragm seal that directly responds to the movement of the supply side (primary) check valve. As the water flow begins (dynamic), the primary check opens and simultaneously frees the diaphragm seal to close off the atmospheric vent and then proceeds to open the secondary check valve (down stream side). The positive supply pressure holds the diaphragm seal in place to close off the atmospheric vent under static (there is no flow, but supply pressure exits in the device) or dynamic conditions. Under back-siphonage conditions, the diaphragm seal is able to open the atmospheric vent independent of the primary check valve (to relieve any vacuum on the supply side). To further understand how an atmospheric vent satisfies a vacuum, put a hole in a soda straw, keeping the hole out of the soda and try to drink the soda.

When a zero pressure or back-siphonage condition exists on the supply side, the primary check valve closes under spring pressure and simultaneously pushes the diaphragm seal into position to form a tight seal between the valve and valve seat-opening the atmospheric vent and closing the secondary check valve.

Under backpressure conditions, the secondary check valve would close first. If the secondary check valve were to foul in the closed position, the primary check valve would close and the backpressure leakage would drain out through the atmospheric vent (air break chamber). (Note: Backflow preventers with atmospheric vents should be located so that water leakage will not cause a nuisance.)

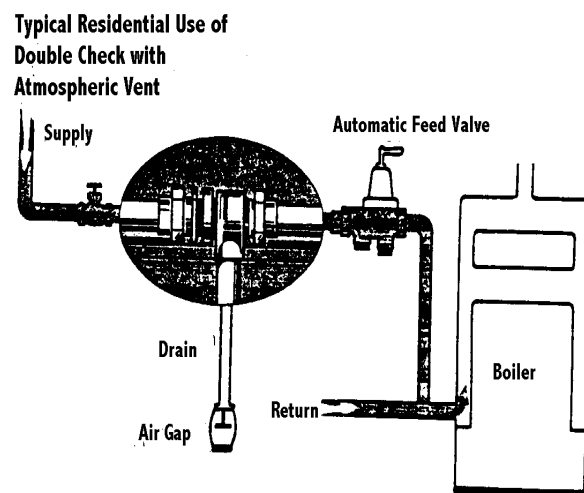
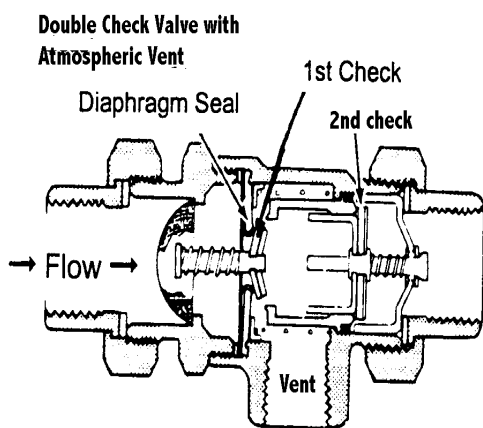

SPECIALTY UNITS WITH AN INTERMEDIATE ATMOSPHERIC VENT FOR & 3/4 INCH SUPPLY LINES, continued

INSTALLATION & USE:

1. The unit can be installed horizontally or vertically and must not be located in a pit or a location subject to standing water. Under no circumstances should plugging of the relief port or vent be permitted.
2. Generally, the unit may be installed on water supply lines for laboratory equipment, food processing tanks, sterilizers, dairy equipment, livestock drinking fountains, residential boilers, or in other situations where cross-connection control is needed.
3. Approved for **LOW HAZARD. CONTINUOUS PRESSURE & BACKPRESSURE OR BACK-SIPHONAGE.** ASSE standard #1012

Note: Some plumbing codes or jurisdictions place application limitations on this device, because the unit cannot be tested.

INTERMEDIATE ATMOSPHERIC VENTS CONTINUED

2. SPECIALTY IN-LINE APPLICATIONS/LAB FAUCETS

These types of backflow preventers operate on the same principle as the backflow preventer with an intermediate atmospheric vent for 1/2 and 3/4 inch supply lines. There are several types of these units and not all of them are approved for continuous pressure.

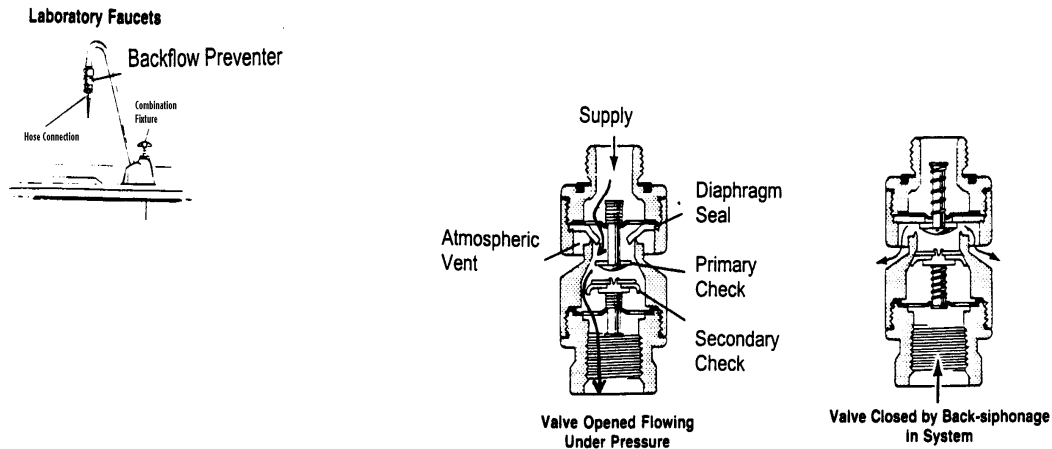

INSTALLATION & USE:

1. Units that are approved for continuous pressure can be used in supply lines for low water volume needs such as coffee and tea urns or icemakers. (Not approved for soda carbonators.)
2. Units that are only approved for non-continuous pressure applications such as those installed on the supply side of an aspirator for a laboratory faucet or on a barber shop/ beauty parlor sink.
3. Whether a particular unit is **APPROVED FOR CONTINUOUS PRESSURE OR NOT WILL NEED TO BE CLARIFIED BY THE MANUFACTURER.**
4. All types are approved for **LOW TO MODERATE HAZARDS AND BACKPRESSURE OR BACK-SIPHONAGE.** ASSE standard #1035

INTERMEDIATE ATMOSPHERIC VENTS CONTINUED

3. **SPECIALTY UNITS FOR BEVERAGE VENDING MACHINES** This backflow preventer is very similar internally to the specialty units for 1/2 & 3/4 inch, and 1/4 & 3/8 inch supplies, except that it has an added ball check valve (after the secondary check valve). The ball check is an extra precaution to prevent carbon dioxide (CO₂) from backflowing (via backpressure) out of a soda carbonator and into any copper supply lines. The CO₂ gas reacts with water to form carbonic acid, which in turn will dissolve the copper lines and thus create possible copper toxicities in those ingesting the water. Any carbon dioxide leaking past the ball check valve and the secondary disc valve would be vented into the atmosphere via the atmospheric vent/air inlet.

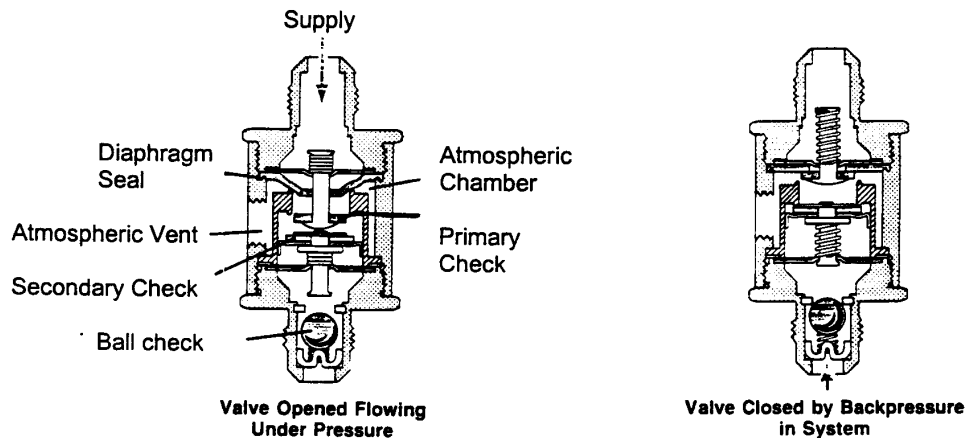
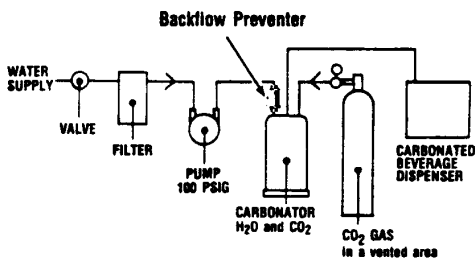

INSTALLATION & USE:

1. The backflow preventer and carbonator system must be located in a well ventilated area. Installation may be horizontal or vertical.
2. The unit may also be used for other beverage equipment such as coffee, tea, and hot chocolate.
3. Approved for **LOW HAZARD- CONTINUOUS PRESSURE & BACKPRESSURE OR BACK-SIPHONAGE.** ASSE standard #1032

REDUCED PRESSURE ZONE BACKFLOW PREVENTION ASSEMBLY (RPZ)

This type of mechanical backflow prevention assembly provides the maximum protection against both back-siphonage and backpressure. Construction of the RPZ consists of two very sensitive, independent, spring loaded check valves with a reduced pressure "zone" between them (at least a 2 psi pressure differential between the "supply pressure" and the "reduced pressure zone"). These check valves are spring loaded to automatically close unless they are held open with flow in the proper direction. As the water passes through the primary check valve, the water pressure will drop (predetermined friction loss/resistance) at least 2 psi in the "reduced" pressure zone or central chamber. Under normal conditions the water will continue through the secondary check valve (only requires 1 psi to open) to the point of usage:

The reduced pressure zone contains a relief valve that drains to the atmosphere and is spring loaded for an automatic open position. The relief valve has the RP zone water pressure on one side and the water supply pressure on the other side. To keep the relief valve closed, the supply pressure must exceed the RP zone pressure. Thus, it will spring open under any conditions causing the water pressure in the "RP zone" to approach or exceed the supply pressure. Also, when the relief valve opens, an air passage from the atmospheric vent to the RP zone is opened to satisfy any back-siphonage conditions. So, even if both check valves are fouled, the relief valve will continue to protect the supply.

Reduced Pressure Zone Backflow Preventer — Principle of Operation

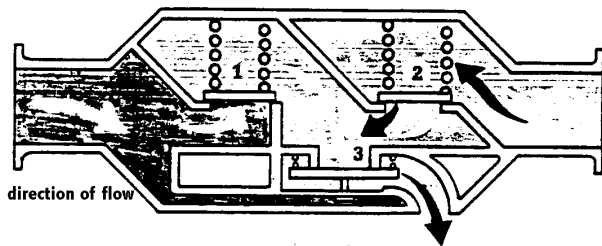

- 1. Primary Check Valve
- 2. Secondary Check Valve

- 3. Relief Valve

Plating Plant Installation

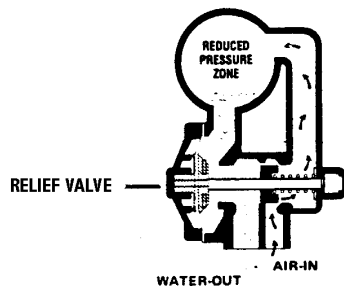
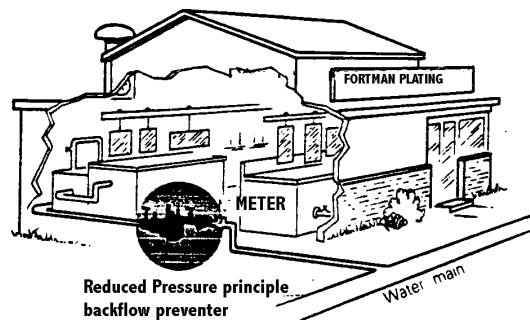

Reduced Pressure Zone Backflow Preventer

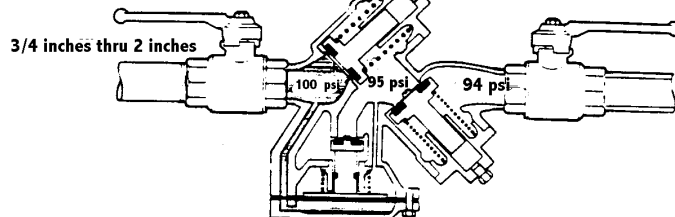

RPZ WATER FLOW AND RELIEF VALVE ACTION WITH VARIOUS SCENARIOS:

1. **BACKPRESSURE** - pressure increases downstream from the backflow preventer. As the downstream pressure approaches the pressure of the "reduced pressure zone", the secondary check valve will close. (Water pressure in the "RP zone" must exceed the downstream pressure in order to hold the secondary check valve open.)
2. **BACK-SIPHONAGE** - approaching zero or negative pressure on the supply side. When the supply pressure approaches zero or negative values, the primary check valve will close; the relief valve will spring open (draining the reduced pressure zone); the atmospheric vent passage to the reduced pressure zone will open; and the secondary check valve will close.

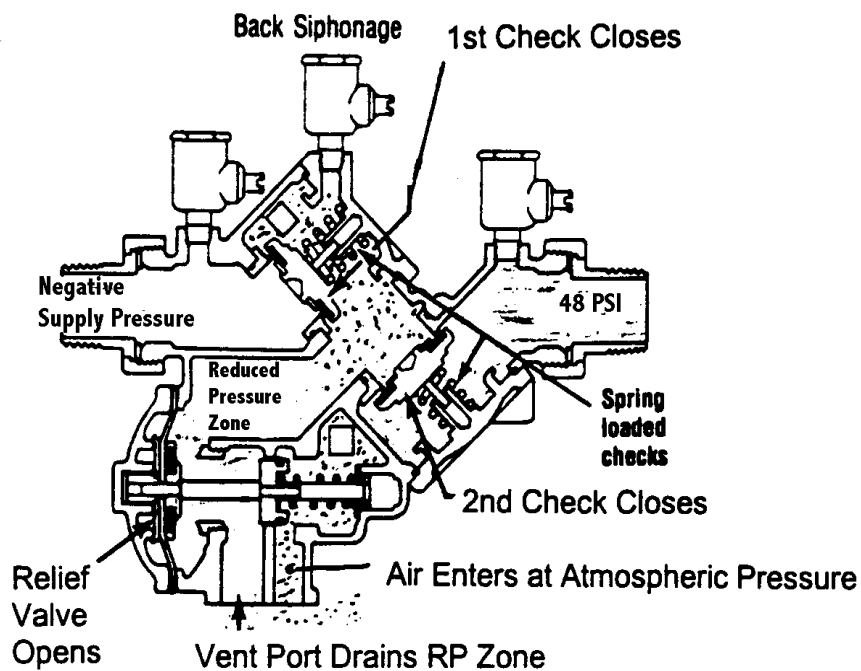

3. **BACKPRESSURE & BACK-SIPHONAGE SIMULTANEOUSLY:** The primary and secondary check valves would close, and the relief valve and atmospheric vent port would open.

4. CHECK VALVES OR RELIEF VALVE MALFUNCTION

Malfunctioning of one or more of the three valves in the RPZ backflow prevent would not compromise the safety of the water supply (but there may be water discharging from the relief port until unit is repaired).

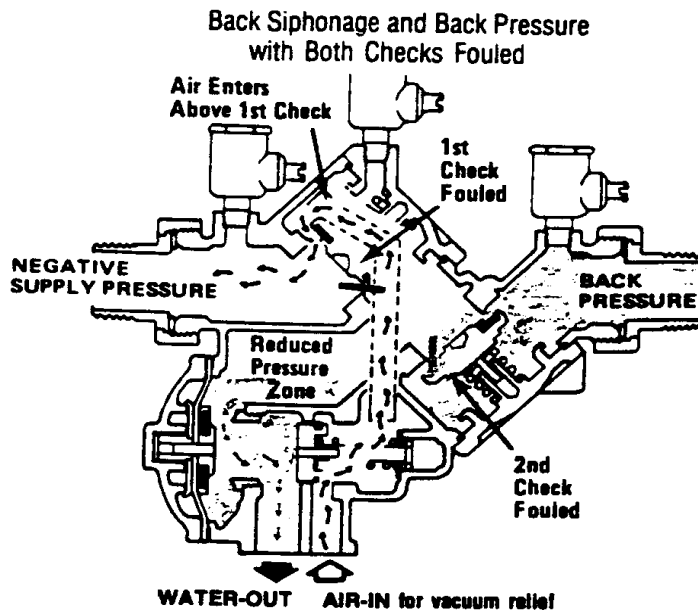

Secondary Check Valve

Backpressure: If some obstruction or wear prevents the secondary check valve from closing tightly, backpressure leakage would increase the central chamber pressure and thus open the relief valve and atmospheric vent port. (As chamber pressure approaches supply pressure, the relief valve springs open.)

Primary Check Valve

Back-siphonage: If the primary check valve were to foul, then simultaneously the relief valve would open, and the air passage from the atmospheric vent port would deliver air to an area just above the primary check valve. The air would satisfy any vacuum caused by back-siphonage. The air flowing to the primary check valve does not use the same passage in the relief valve used for draining water.

Backpressure: If the primary and secondary check valves were to fail simultaneously, then the water leaking back into the central chamber would exit through the relief valve.

Relief Valve/Port

A malfunctioning relief valve will not close; it will remain open, discharging water through the port until repaired. Even when fouled, the supply remains protected.

RPZ INSTALLATION & USE:

1. Under no circumstances should plugging of the relief port be permitted.
2. The RPZ is equipped with test cocks and gate valves to enable required unit testing.
3. Several unit sizes are available for 3/4 to 10-inch supply lines. Approximate pressure losses across the unit are 10 to 20 psi, depending on the size and flow rate.
4. Install on each high hazard connection within a secondary system and/or at the service connection or water meter (for containment on the property) of car washes, autopsy and funeral parlors, commercial boilers, cooling towers, hospital and laboratory equipment, processing tanks, sewage treatment, etc.
5. The unit must be accessible for testing and service, and must be located above grade (not subject to flooding). The device must be installed at least 12 inches from any wall and between 12 to 30 inches above the floor.
6. Approved for **HIGH HAZARDS, CONTINUOUS PRESSURE, BACKPRESSURE OR BACK-SIPHONAGE.** ASSE standard #1013

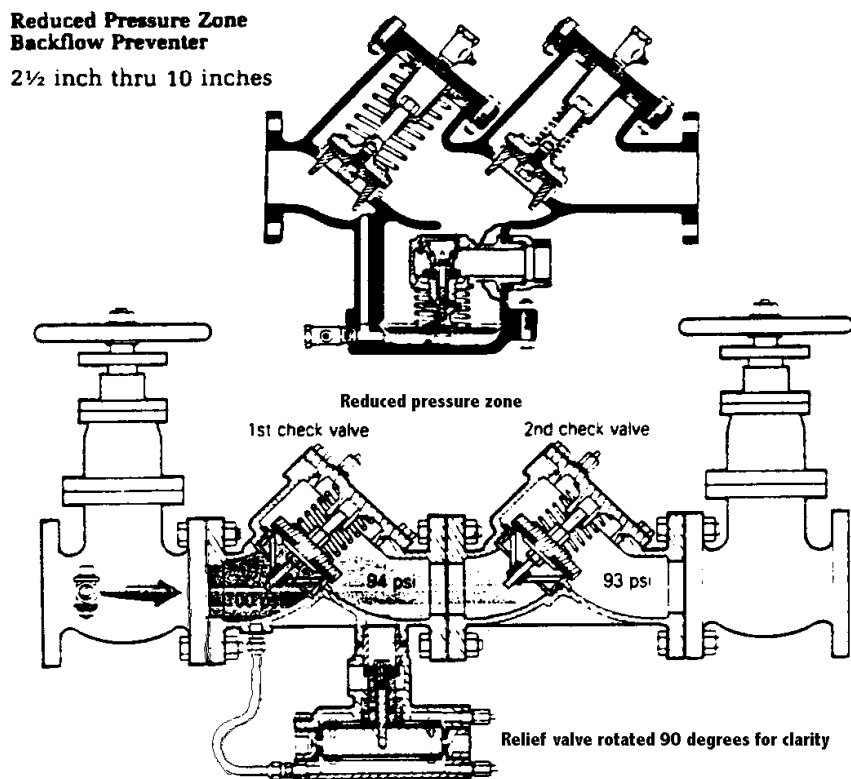

DOUBLE CHECK VALVES

A double check valve backflow preventer consists of two check valves that are spring loaded in the closed position. These devices do not have the added protection of an atmospheric vent and therefore are limited to the amount of protection they offer and how they can be used. Some jurisdictions and codes do not permit double check valves to be used for backflow protection.

INSTALLATION & USE:

1. Double check valves can only be used where they are approved for limited use with low hazard, continuous pressure conditions.
2. **THREE TYPES OF DOUBLE CHECK VALVES:**

I. DOUBLE CHECK VALVE

This type of device is designed for commercial applications for 3/4 to 10-inch supply lines and contains test cocks and gate valves for testing purposes. ASSE standard #1015

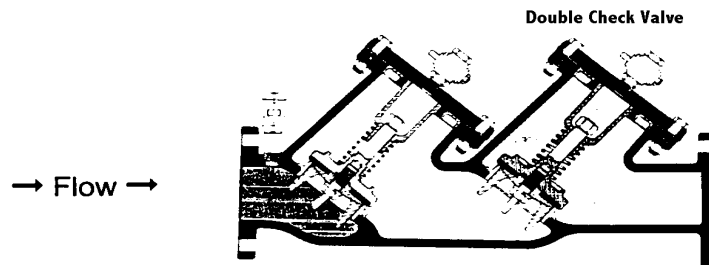

I. DOUBLE CHECK DETECTOR CHECK VALVE

This device is similar to the "double check" unit except that it has a water meter added to detect down stream leaks and unauthorized withdrawals. The unit is commonly installed on fire protection supply mains. ASSE standard #1048

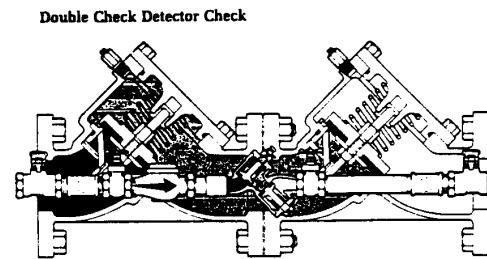

III. DUAL CHECK VALVE The dual check valve is for residential applications only. When used, it is usually installed on the customer side of the water meter in an attempt to contain any pollutant (low hazard) within the resident's secondary system. The dual check valve is not equipped for in-line testing. ASSE standard #1024

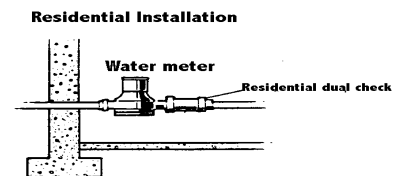
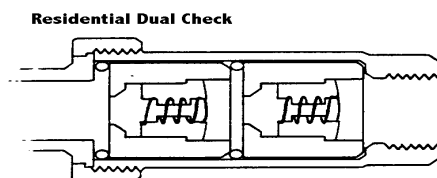

VII. TYPICAL RETAIL FOOD SERVICE CROSS-CONNECTIONS

NOTE: When evaluating the potential plumbing hazards for each fixture, there may be more than one type of backflow assembly or device that can be installed to protect a cross-connection (even if it exceeds minimum requirements to meet the hazard). In lieu of an air gap, is a cross-connection subject to backpressure and continuous or non-continuous pressure (all are subject to back-siphonage)? All inlets and cross-connections attached to the water supply are subject to back-siphonage, but not all are subject to backpressure. For specifications on proper installation and use for each device, review the previous pages.

The following are "typical" examples of equipment and backflow prevention devices required in lieu of an air gap. Remember, sometimes plumbing installations can be construed in a "nontypical" fashion; this does not mean that is necessarily wrong, but it will take more effort to evaluate the cross-connection control design.

1. **Prerinse or preflush hose:** (typically located at garbage grinders/disposals, pre-rinse or flushing stations prior to mechanical warewashing machines, or vegetable/prep sinks)

Units that are not equipped with a proper retainer spring (so an air gap above the flood level rim can be maintained when allowed to hang freely) must be provided with an appropriate backflow assembly or device. The type installed is dependent on the shut off valve location:

- a. Hand valve on spray nozzle: Since the entire supply line is subject to continuous pressure, the backflow device must be acceptable for use with continuous pressure and back-siphonage application. Backpressure is not an issue for a potential indirect cross connection. An in-line double check valve assembly with an intermediate atmospheric vent or pressure vacuum breaker (PVB) can meet the minimum requirements for continuous pressure.
- b. No valve on the spray nozzle or end of hose: The supply line from the shut off valve to the end of the nozzle is not subject to continuous pressure or backpressure. An atmospheric vacuum breaker (AVB) can meet the minimum requirements for non-continuous pressure and potential back-siphonage.

2. **Hose bibbs, threaded faucets** (inside & outside of establishment, fairgrounds, special vents, festival, etc.):

When a hose is attached directly to the faucet, a potential indirect cross-connection exists. Protected will depend on whether or not a shut-off device (pistol grip, etc.) is installed on the end of the hose.

- a. No shut off device on the end of the hose: The hose is not subject to continuous pressure or backpressure. A hose bibb vacuum breaker (HBVB) or atmospheric vacuum breaker (AVB) can meet the minimum requirements for non-continuous pressure and potential backsiphonage.

- b. A shut off device on the end of a hose: The backflow device is subject to continuous pressure and no backpressure. An in-line backflow prevention device with an intermediate atmospheric vent or a pressure vacuum breaker (PVB) can meet the minimum requirements for protection. (Note the PVB must be installed at least 12 inches above the maximum expected height that the hose end will be utilized.)

3. **Inlets which are or may become submerged:**

- A. Supply lines for a mechanical warewashing machine and dish conveyor belt.
- B. Supply inlet to a dish table trough or silverware and dish soak tanks.
- C. Supply line to a soap dispenser (detergent feeder) and/or drying agent for mechanical warewashing machines: The dispenser discharges the solution on the down stream side of AVB for the warewashing machine's supply line.
- D. Supply inlet to a garbage disposal with flushing rim: The submerged inlet is controlled by an electronic solenoid that supplies water to the waste being ground to form a slurry whenever the disposer is turned on.
- E. Garbage can washer. (If a jet rinse type, the inlet through the floor must be at least six inches above the flood level rim of the depressed area/sink).
- F. Perforated pipes to an oriental wok cooker.
- G. Supply inlet or fill line for equipment such as steam kettles, steam tables, dipper wells and coffee urns.

Backflow prevention for items A-G: Typically the atmospheric vacuum breaker is utilized on a submerged inlet for non-continuous pressure and potential back-siphonage. For continuous pressure and potential back-siphonage (no backpressure), a pressure vacuum breaker (PVB, can meet the minimum requirements for protection.

Inlets which are or may become submerged, Continued:

- H. Soap portioner on a faucet:
The soap portioner must contain an internal air gap.
- I. Water wash system for an exhaust hood (self cleaning):
Detergent feeder must discharge on the down stream side of the backflow prevention device and have an AVB for non-continuous pressure, PVB for continuous pressure or an in-line backflow prevention device with an intermediate atmospheric vent for continuous pressure and potential backpressure. A reduced pressure zone (RPZ) backflow prevention device may be required if toxic chemicals are added.

4. **Carbonators; for beverage dispensers:** Carbon dioxide (CO₂ from the carbonator that comes into contact with water will form carbonic acid (weak acid). If carbonic acid comes into contact with copper piping, copper will dissolve into the water and may result in copper poisoning (vomiting). Typically, the hazard exists for those consuming the first few softdrinks of the day. To prevent the backpressure of CO₂, an in-line backflow prevention device with an intermediate atmospheric vent meeting ASSE Standard #1022 **must be installed between the carbonator and any copper supply line.**

5. **Boiler:**

a. with no chemicals added:

An in-line backflow prevention device with an intermediate atmospheric vent for continuous pressure and potential backpressure.

b. with chemicals added (high hazard):

A reduced pressure zone (RPZ) backflow prevention device would be required for toxic chemicals with potential backpressure and continuous pressure. The water supply line for the chemical additive reservoir must also be adequately protected.

6. **Water softening equipment:** with a continuous feed to a brine tank requires at least an in line backflow prevention device with an intermediate atmospheric vent to meet the minimum protection for continuous pressure.

7. **Lawn sprinkler system** with no potential backpressure: An AVB for non-continuous pressure and a PVB for continuous pressure would meet minimum requirements for backflow protection. If chemicals are added a RPZ may be required.

TYPICAL MECHANICAL WAREWASHING INSTALLATION

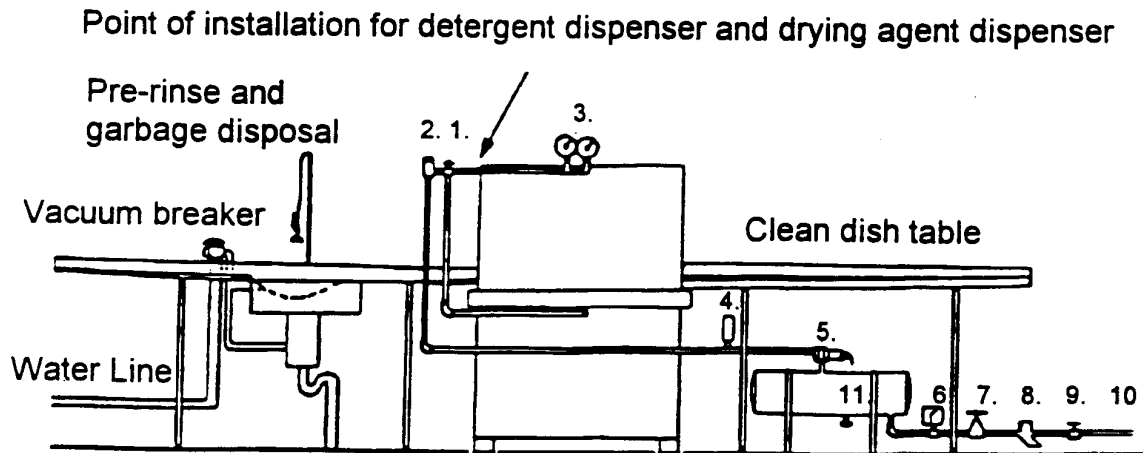

1. Gauge cock for tests
2. Vacuum breaker
3. Wash and final rinse gauges
4. Shock arrestor (recommended)
5. Pressure-temperature relief valve
6. Pressure-temperature gauge
7. Pressure reducing valve (set at 15-25 psi)
8. Strainer
9. Cut- off valve
10. 140 degree water supply
11. Booster heater

VIII. AIR GAES & AIR BREAKS FOR DRAINS & WASTE

An indirect connection between the water supply or food service equipment and the facility's drainage or wastewater disposal system is necessary to prevent wastewater from backflowing (back-siphonage or backpressure) into the supply or into equipment where food, kitchenware or utensils are retained.

DIRECT CONNECTION: A waste line or pipe from a fixture, receptacle or device that discharges used water, waste materials or sewage directly into the facility's drainage system.

INDIRECT CONNECTION: A waste line or pipe from a fixture, receptacle or device that discharges used water, waste materials or sewage into the facility's drainage system through an "air gap" or "air break." Thus, there is no direct connection between the two systems.

AIR GAP: is the unobstructed, vertical air space that separates the end of a supply-line and the flood level rim of a receptacle. This receptacle may be a sink, coffee urn, steam kettle, floor drain, floor sink, etc. The air gap must be the greater of the two - a minimum of one inch or twice the inside diameter of the supply pipe.

AIR BREAK: is a waste line or pipe from a fixture that discharges used water or liquid waste into another fixture or receptacle at a point below the flood level rim, i.e., the waste line from a vegetable preparation sink that drains into a floor drain. (Restated: an air break is an indirect connection that does not have an "air gap.") (*Note: some jurisdictions do require the waste line to terminate above the flood level rim of the floor, sink or drain.*)

- 1. Booster heater for warewashing machine:**
Provide an air gap between the relief valve vent pipe and the floor drain or floor sink.
- 2. Waste-cooled condenser for an ice machine or other refrigeration system:**
Provide an air gap between the end of the supply line and the floor drain or floor sink. (The supply line water still remains as part of the supply system as it cools. The cooling water is not exposed to potential outside contamination until it exits the unit.)
- 3. Drain lines for food service equipment** such as salad cooler table or salad bar, ice machine or ice bin, soda fountain/dispenser, steam kettle and steam table: Provide an air break.
- 4. Condensate drain lines** for refrigeration equipment: Provide an air break.

5. Water softening equipment:

- a. Brine tank drains through a hose bibb (potential indirect cross-connection with a drain hose): a hose bibb vacuum breaker (HBVB) can meet the minimum requirements for non-continuous pressure and potential back-siphonage.
- b. Brine tank with a gate or ball valve: drain line must be air gapped.

6. Exceptions to indirect wastes:

- a. Warewashing machines located within five feet of a trapped floor drain may have a direct waste connection to inlet side of a properly vented floor drain trap.
- b. Garbage disposals require a direct connection to prevent the solids from separating out from the waste slurry.
- c. Other exceptions as provided by law or regulation.

IX REFERENCES & RESOURCES

- 1 American Society of Sanitary Engineering (ASSE)
28901 Clemens Road, Suite 100 (216) 835-3040 fax (216) 835-3488
Westlake, OH 44145 E-mail: ASSE@IX.netcom.com

ASSE Standards for Cross-ConnectIon Control

- 1001 - Pipe Applied Atmospheric Type Vacuum Breakers, ASSE/ANSI - 1990
- 1002 - Water Closet Flush Tank Ball Cocks, ASSE - 1986
- 1011 - Hose Connection Vacuum Breakers, ASSE/ANSI - 1995
- 1012 - Backflow Preventer with Intermediate Atmospheric Vent, ASSE/ANSI - 1995
- 1013 - Reduced Pressure Principle Backflow Preventers, ASSE - 1993
- 1015 - Double Check Backflow Prevention Assembly, ASSE - 1993
- 1019 - Vacuum Breaker Wall Hydrants, Freeze Resistant Automatic Draining Type,
ASSE/ANSI - 1995
- 1020 - Pressure Vacuum Breaker Assembly, ASSE/ANSI - 1990
- 1021 - Drain Air Gaps for Domestic Dishwasher Applications, ASSE - 1977
- 1022 - Backflow Preventer for Carbonated Beverage Machines, ASSE - '1996
- 1024 - Dual Check Valve Type Backflow Preventers, ASSE - 1994
- 1032 - Dual Check Valve Type Backflow Preventers, ASSE -1980 (carbonating units)
- 1035 - Laboratory Faucet Backflow Preventers, ASSE/ANSI - 1995
- 1047 - Reduced Pressure Detector Backflow Preventer, ASSE/ ANSI - 1995
- 1048 - Double Check Detector Assembly Backflow Preventer, ASSE/ANSI - 1995
- 1052 - Hose Connection Backflow Preventers, ASSEIANSI -'1994
- 1055 - Chemical Dispensing Systems, ASSE - 1997
- 1056 - Back-Siphonage Backflow Vacuum Breakers, ASSE/ANSI - 1995
- 1060 - Outdoor Enclosures for Backflow Prevention Assemblies, ASSE - 1996

Prepared By: N.C. Food, Lodging, and Institutional Sanitation Branch
Plan Review Subcommittee

3. American Water Works Association (AWWA)
6666 West Quincy Avenue (303) 794-7711
Denver, CO 80235
Homepage: <http://www.awwa.org>
3. FEBCO
P.O. Box 8070(209) 252-0791 fax (209) 453-9030
Fresno, CA 93747-8070 Homepage: <http://www.cmb-ind.com>
4. Foundation for Cross-Connection Control and Hydraulic Research
University of Southern California (213) 740-2032 fax (213) 740-8399
KAP-200 University Park MC-2531 E-Mail: fccchr@usc.edu
Los Angeles, CA 90089-2531 Homepage: <http://www.usc.edu/dept/fccchr>
5. Plumbing and Drain Institute (PDI)
1106 West 77 1h Street South Drive
Indianapolis, IN 46260 (317) 251-6970
6. Plumbing Related Associations & Publications
Homepage: <http://www.PlumbingSupply.com/public.html>
7. Wafts Regulator Company
815 Chestnut Street (508) 688-1811 fax (508) 794-1848
North Andover, MA 01845
Homepage: <http://www.waftsreg.com>
8. Zurn Industries, Inc.
Hydromechanics Division
1801 Pittsburgh Avenue
Erie, PA 16514 (814) 455-0921 fax (814) 454-7929
9. Food and Drug Administration
Division of Human Resource Development
5600 Fishers Lane, HFC-61
Rockville, Maryland 20857 (495) 443-5871