

FOCUS

Providing current pollution prevention information to North Carolina industries

Energy Efficiency for Peak Performance A Reference for Facility Energy Savings

Since the oil crisis in the early 1970s, energy efficiency continues to be a top priority in effective plant and facility operations. Industry accounts for 36 percent of primary energy use in the United States. The industrial sector is diverse, with a wide range of processes, energy requirements and pollution issues. Industries may not generally perceive energy as a separate issue, but as a component of broader concerns such as cost of manufacturing, environmental compliance, safety and productivity. Energy efficiency competes with other matters for limited resources such as capital and staff time within a company. However, effective energy management can save a facility or thousands of dollars annually. energy saving tasks are at low or no cost. The “low-hanging fruit” with the quickest payback time, such as insulating bare pipes, can serve to build confidence and lead to more capital-intensive projects.

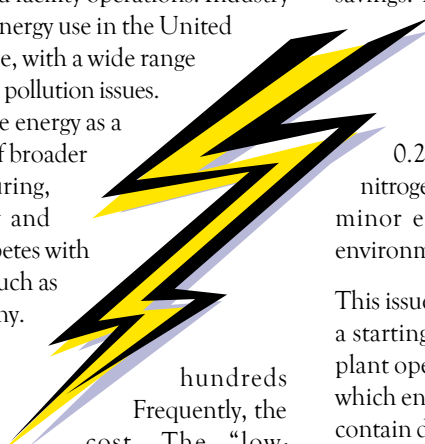

Improving energy efficiency is more than just energy and dollar savings. The environmental benefits of using less energy result in decreased demand on natural resources and generation of pollutants. It has been estimated that on average in the United States for every kilowatt-hour of electricity saved (not generated) 1.5 pounds of carbon dioxide (CO₂), 0.2 ounces of sulfur dioxide (SO₂), and 0.09 ounces of nitrogen oxide (NO_x) are not released into the atmosphere. Even minor energy efficiency improvements can help to reduce environmental impacts.

This issue of FOCUS: Waste Minimization is intended to provide a starting place for facility managers pursuing energy savings in plant operations. Energy efficiency is an overwhelming topic for which enormous amounts of information exist. These eight pages contain discussions, contacts and resources that can assist the user on identifying wasteful operations and determining energy-saving options to minimize energy use without sacrificing required process conditions or occupant comfort. ■

Improving Lighting Efficiency

Improving the efficiency/effectiveness of lighting systems, both interior and exterior, is a basic component of an energy management program. Lighting is usually one of the first items addressed simply because it is an easily understood subject with which everyone is familiar. Lighting enhancements are usually inexpensive and easy to implement, and generally fall into two major categories: increasing system efficiency and optimizing system controls.

Increasing system efficiency means not only using a more efficient source, but also improving the delivery system; i.e. how the luminaire, lamp, reflector and lens all work together to get the light to the desired location. For example, converting fluorescent systems to T-8 (26 millimeter) lamps and electronic ballasts has been a widely-applied practice for a number of years, as has replacing incandescent fixtures with fluorescents, mercury vapor with metal halide or high-pressure sodium, and other similar retrofits. These upgrades focus on increasing the efficacy of the

source (lumens of light delivered/watts of power input) and result in lower peak electrical demand (kilowatts) and reduction in energy consumption (kilowatt hours).

see IMPROVING EFFICIENCY, page 7

INSIDE THIS ISSUE



The Fourth Utility	2
Optimize Chiller Operations	3
Make Your Energy Bills Pay You	4
N.C. Industry Energy Champion	5
Be an ENERGY STAR	6
Utility Provider Resources	6
Media News Update	7
Meet DPPEA's Energy Manager	8
Calendar of Events	8

The Fourth Utility

Compressed air is used widely throughout industry and is often considered the "fourth utility" behind electricity, gas and water.

In many industrial processes air compressors use more electricity than any other type of equipment. However, the operating fees of this "fourth utility" are typically not known or tracked. Since the cost of compressed air is hidden, much of the resource may be wasted. Plant managers know how much was paid for the air compressor, but have no

idea that the yearly electric operating cost may equal or exceed the original purchase price. Compressed air systems account for \$1.5 billion annually of the total U.S. energy costs.

Inefficiencies in compressed air systems result in significant financial losses. System improvements can result in reducing electricity consumption by 20-50 percent that can equate to annual savings of thousands of dollars. A properly managed compressed air system can save energy, reduce maintenance, decrease downtime, increase production and improve product quality. The following are low-cost energy-saving tips for air compressors.

- Inform employees of the value of this utility and how not to be wasteful.
- Operate a minimum number of compressors for the load.
- Avoid using compressed air for agitation, cleaning or work area air conditioning.
- Shut off compressed air to equipment that is not in use.
- Post signs around the compressors to remind employees to shut off during down times and display the costs of operation and misuse.
- Control antisurge valves with flow rather than pressure and keep them closed.
- Reduce the system pressure to the minimum necessary.
- Monitor stage pressures and temperatures to detect problems.
- Recover heat from aftercoolers to generate hot air/water (80 percent of the electricity going to a compressor becomes heat).

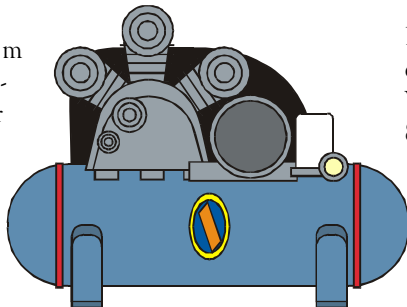

AIR LEAKS = WASTED ENERGY

a $1/16$ " leak at 100 psi
wastes 16.6 kWh electricity
and costs \$1 per day

(Costs of labor to find/repair leaks and fitting replacement not included in estimate)

Inadequate maintenance can also have a significant impact on energy consumption by lowering compression efficiency, leaking air or varying pressure. Compressed air system maintenance is comparable to that of a car; filters and fluids must be replaced, cooling water is inspected, belts are adjusted, and leaks are repaired. Most importantly is that all equipment in the compressed air system be operated in accordance with manufacturer's specifications. The

following are basic maintenance checks for air compressors:

- Inlet filter cartridges: inspect, clean and change as necessary.
- Drain traps: clean out and check operation periodically.
- Compressor lubricant level: inspect daily and replenish as necessary.
- Lubricant selection: compressor and motor lubricant should be chosen according to manufacturer's specifications.
- Belts: examine and adjust (typically after 400 hours of use).
- Operating temperature: verify level is per manufacturer's specifications.
- Air line filters: replace particulate and lubricant removal elements when pressure exceeds 2 to 3 psi. Inspect all filters annually, regardless of pressure.
- Water cooling system: check water quality for pH, total dissolved solids, flow and temperature. Clean/replace filters per manufacturer's specifications.
- System leaks: check lines, especially joints, fittings, clamps, valves, hoses, disconnects, regulators, filters, lubricators and end-of-use equipment for leaks.
- System cleanliness: inspect system for compressor and motor lubricant leaks and cleanliness.

For additional information on increasing the efficiency of compressed air systems, contact Rudy Moehrbach with the Waste Reduction Resource Center at 919-715-6553, 800-476-8686 or Rudy_Moehrbach@p2pays.org. Several fact sheets on improving operations of air compressors are available at the Department of Energy's Compressed Air Challenge™ site at www.knowpressure.org/html/where.html. ■

Optimize Chiller Operations

Centrifugal chillers are workhorses of industry, supplying cooling to many industrial plants. Most units are manufactured in the range of 150 to 300 tons capacity. Their popularity comes in part because of their low energy cost per ton of cooling produced relative to other chiller types. Typical full-load efficiencies for new chillers, rated at standard ARI (Air Conditioning and Refrigeration Institute) operating conditions, range between 0.50 and 0.62 kW/ton.

However, a serious drawback to centrifugal chillers is their part-load performance. When the plant load decreases, the chiller compressor responds by partially closing its inlet guide vanes to restrict refrigerant flow. While this control method is effective down to about 20 percent of the chiller's rated output, it results in decreased operating efficiency. For example, a chiller rated at 0.60 kW per ton at full load might require as much as 0.90 kW per ton when lightly loaded. Since chillers typically operate at or near full load less than 10 percent of the time, part-load operating characteristics greatly impact annual energy use.

1,200 and 800 tons, all three chillers share the load and operate between 100 and 67 percent of full load. At these loads, their part-load efficiency will vary between 0.52 and 0.65 kW/ton.

As the load falls below 800 tons, Chiller #3 is taken off-line. As the load modulates between 800 and 400 tons, Chillers #2 and #1 equally share the load and have part-load efficiencies between 0.52 and 0.70 kW per ton.

As the load falls below 400 tons, Chiller #2 will be shut down. Below 400 tons, Chiller #1 will operate between 100 and 50 percent with respective efficiencies of 0.52 to 0.75 kW/ton. All chillers are turned off when the load gets to 200 tons and plant cooling is provided by outside air economizers.

When the cooling load increases, the chillers automatically start in reverse order. The optimum chiller sequencing strategy enables the chillers to operate at relatively high part-load, never allowing the efficiency of any chiller to fall below 0.75 kW/ton. Again, this sequencing is how the control strategy is supposed to work.

Often, outside factors offset the control strategy's savings. A common problem that plagues chiller sequencing is improper chiller isolation. This can occur abruptly or gradually over time with the failure of the chiller's isolation valves. Sometimes isolation valves are inadvertently left out of the system design.

If the off-line Chiller #3 is not completely isolated, the primary loop water will be pumped through Chiller #3. In this example, the primary loop provides 3,000 gallons of 45° F supply chilled water with 55° F water returned to the chillers. Improper isolation on Chiller #3 will allow 1,000 gallons of 55° F water to circulate through it and blend with the 2,000 gallons of 45° F supply chilled water from Chillers #1 and #2. The blended 3,000 gallons of supply water will be slightly over 48° F. In order for the primary chilled water loop to provide the required 45° F chilled water, Chillers #1 and #2 must produce 40° F supply chilled water.

Improper isolation causes the on-line chillers to produce colder water than required, drastically reducing their efficiency. Improper isolation also impedes the on-line chillers' ability to load and unload. The chiller sequencing control system may call for more chillers than are needed, resulting in further system efficiency reduction.

Chiller sequencing controls do work; however, periodic preventative maintenance and complete chilled water system checkout is necessary to ensure that this control strategy continues to provide energy and operating cost savings.

Charles Martin, PE, is the chief consultant with energy services of the Foresight Group. Mr. Martin can be reached at 919-858-8335, cmartin@foresightgroup.net. Additional energy saving tips for heating, ventilation and air conditioning systems are available at http://energy.com/Resources/Tips_For_Consumers/hvac.asp. ■

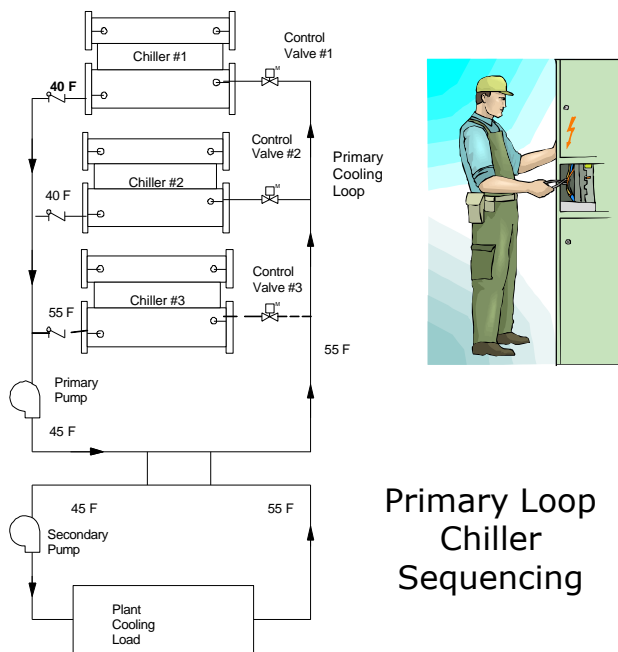

To offset the problem of poor part-load performance, multiple centrifugal chillers may be used in a cooling plant. An optimum chiller sequencing control strategy dispatches the chillers to effectively manage their part-load performance.

The strategy is meant to work like this: a facility depicted by the diagram has a 1,200-ton cooling load. Three 400-ton chillers supply cooling to a primary chilled water loop. Cooling is extracted from the primary cooling loop by a secondary loop that supplies the various plant cooling loads.

The chillers are brought on- and off-line by the chiller sequencing controller to meet the ever-changing plant cooling load. Between

Make Your Electric Bill\$ Pay You

Close review of your electric bill may reveal that certain charges can be reduced or even eliminated. Companies exist whose sole business is to review and correct firms' electrical bills in return for a percentage of the savings. Many companies accept energy bills as just another cost of doing business without reviewing accuracy or any potential for electrical usage reduction. Failing to analyze energy usage can cost large amounts of money in missed energy savings.

Every electric power-using facility, whether a school or manufacturer, is billed using one of several rate schedules available from its utility company. Below is a simplified example of a typical rate schedule:

MR. ENERGY MISER MANUFACTURER'S RATE SCHEDULE

CUSTOMER SERVICE:

Base Monthly Charge \$50.00/month

ENERGY USAGE CHARGE:

First 10,000 kWh* \$0.050/kWh

10,001 to 200,000 kWh \$0.045/kWh

All over 200,000 kWh \$0.040/kWh

Fuel Charge \$0.005/kWh
(fuel used by the utility)

* Kilowatt Hours (kWh): Amount of power used during the billing period, usually monthly.

DEMAND**/CAPACITY CHARGE:

Billed Demand \$8.50/kW
(whichever is highest of the list below)

Actual
(actual demand value recorded on the customer's meter)

Contract
(charge for minimum percent below anticipated peak demand)

Coincident Peak
(charge when utility is at peak capacity)

Non-coincident Peak
(max facility charge regardless of time)

Ratchet
(charge based on the highest peak demand within the last 12 months)

Minimum
(set bottom charge even if facility is closed)

** Demand = Kilowatts (kW): Rate of power the facility needs.

POWER FACTOR CHARGE:

Demand is increased by 1 percent for each 1 percent the power factor is less than 80 percent***

***Power Factor: The actual Power Kilowatts (kW) used per Apparent Power (kVa), usually called the cosine.

TAXES:

All charges are subject to a 10 percent sales tax

TOTAL ELECTRICAL BILL =

Customer Charge + Capacity/Demand Charge
+ Energy/Usage Charge + Taxes

Know Your Peak Times. Rate schedules can be complicated even more by special capacity and rate charges based on peak and off-peak hour electricity demands and usages. Utility companies have established specified intervals of time to measure the electricity a facility uses. The electric meter measures the kilowatts in "demand intervals" which are typically 15 minutes for CP&L and 30 minutes for Duke Power. An electric company can provide a graph of demand and electricity usage to evaluate the occurrence and causes of peaks. For example, an insurance company required a factory to test the emergency fire protection pumps monthly for thirty minutes. The company established a schedule so that on the last Friday of every month during first shift the pumps were turned on for thirty minutes. Because of the additional 600 kW these pumps pulled on the electric meter, the factory paid an extra \$43,000 per year in unnecessarily high demand charges. Analysis of demand graph showed the increased demand during the peak hours for just the thirty minutes. As a result of the analysis, the pumps are now tested on third shift during low electrical demand.

The demand charge is "ratcheted," that is it is based on the highest peak demand in any one of the past 12 months, and is charged each month, even though the actual demand for any given month may be below the highest peak demand. Typically, upon customer request, utility companies will help determine the lowest and best rate schedule possible. Most utilities also offer a service that finds energy saving opportunities in operations.

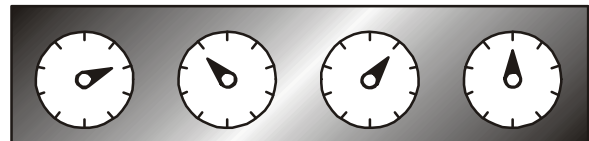

Meter Reading. Other costly electric bill situations can occur if the meter is misread. One small company's example was that each month, the utility company meter reader replaced the chart paper for the circle chart electric meters. The chart was read back at the utility company and a bill prepared. Over time, the meter's pen may not have been replaced, making the marks on the chart thicker and difficult to read. The inaccurate readings resulted in the facility being charged more than necessary. If a meter is blocked or obscured, it is typically read from an angle. False readings can raise the costs of a company's electric bill.

Electric bills and electric bill data can be easily studied to find where electricity is being wasted or used at inappropriate times. This can lead small businesses and companies to tens of thousands of dollars a year in electric bill savings. For larger facilities it can mean saving hundreds of thousands of dollars annually. Remember, evaluate your monthly statement for potential savings! ■

N.C. Industry Energy Champion

Company Improves Manufacturing Efficiency.

M. J. Soffe Co., a Fayetteville clothing manufacturer, knows that energy cost savings are key to remaining competitive in its industry. As Soffe's business grew, production increased costs for fuel and electric utilities. When planning facility additions, Soffe chose to install energy efficiency devices that provide energy savings and productivity improvements. Energy training for facility employees also provides the skills and knowledge needed to keep all systems running at optimum levels.

Energy Use Evaluations. Soffe uses a constant supply of hot water to dye, set and wash its product. As business grew, production increased hot water needs faster than the 25,000-gallon tank could make available. Dye workers often depleted hot water reserves and were forced to halt production while fresh water was heated with steam in the dye machines. Not only did the lack of hot water lead to decreased productivity, it also caused problematic issues with material dyes in the fabric.

In 1997, Soffe's maintenance manager attended energy efficiency workshops hosted by the State Energy Office (formerly of the Department of Commerce) of the N.C. Department of Administration and North Carolina State University's (NCSU) Industrial Extension Service. Eager to enhance both manufacturing efficiency and energy use, Soffe worked with NCSU energy program experts to develop solutions to save the company money and increase productivity. NCSU specialist engineers examined the plant's heating, ventilation and air conditioning systems, chiller and cooling towers, steam traps and boilers. Several areas for improvement were identified, including dye house operations, the efficiency of the air conditioning system, modifying lighting in the company warehouse, and improving air compressor efficiency. The two most obvious energy drains on Soffe's manufacturing process were water heating and steam leaks.

Energy Reductions. NCSU and Soffe developed a wastewater heat recovery system using heat from used dye water. Wastewater is held in one 25,000-gallon storage tank. As another storage tank is filled with water from the city water system, it passes

through a system that runs both cool water and wastewater through a heat exchanger. Heat from the wastewater warms the fresh water to about 120° F, just 20° F below the ideal temperature for dyeing cotton. The constantly hot water produces more precise dyeing and garments washed in 140° F water do not suffer dye bleeds the way they do in 95° F water. "Our dye house manager has said that capacity is up 15 percent and quality, especially on white garments, is up by 15 percent as well," stated Soffe maintenance manager, Adrian O'Quinn.



Steam leaks also remained a problem. With steam escaping into the workplace air, steam leaks made heating the buildings difficult, taxed the air conditioning system, and caused Soffe to run the steam at inefficient high pressures. The leaks were identified and repaired. A steam trap and condensate

return system were installed to keep leaking steam and moisture in the system. An occupancy-based lighting power control system was also installed in the company's new 127,000 square foot warehouse. The new system also uses daylighting as much as possible.

Energy Savings. Fuel costs for the water boiler through the first seven months of 1999 were down 42 percent, saving over \$100,000. Soffe did not need to purchase a direct contact water heater, saving equipment as well as energy costs. Reduced steam pressure along with improved efficiency provided modest fuel savings of \$2,600 in 1998. The redesigned and modified condensate return system provided annual savings of \$14,000. Water conservation upgrades saved \$10,000 on the napping machines, despite rate increases in water and sewer service. Improved air compressor efficiency reduced energy and maintenance costs by almost \$11,000. The new warehouse lighting system is estimated to reduce annual power use by 158,750 kWh, saving \$12,700 annually.

How to Reach NCSU. For more information on the Energy Management Program and its services, please contact Jim Parker, program director, at 919-515-5438 or at jim_parker@ncsu.edu. Visit the Industrial Extension Service Web site at <http://www.ies.ncsu.edu/energy>. ■

FOCUS: Waste Minimization is published by the divisions of Pollution Prevention and Environmental Assistance, Waste Management, Air Quality, and Water Quality of the N.C. Department of Environment and Natural Resources (DENR). It is intended to provide North Carolina industries and other interested parties with current information concerning proper waste management and waste reduction. The information contained in this publication is believed to be accurate and reliable. However, the application of this information is at the reader's own risk. Mention of products and services in the publication does not constitute an endorsement by the State of North Carolina. The information contained in this publication may be cited freely.

If you have comments, waste minimization case summaries, resource information, or questions for the next issue of the FOCUS newsletter, call Norma Murphy at (919) 715-6513, fax (919) 715-6794, e-mail Norma.Murphy@ncmail.net or write the N.C. Division of Pollution Prevention and Environmental Assistance (DPPEA), 1639 MAIL SERVICE CENTER, RALEIGH NC 27699-1639.

State of North Carolina: James B. Hunt Jr., Governor; Bill Holman, DENR Secretary; Gary Hunt, DPPEA Director.



Visit
DPPEA
online:

www.p2pays.org

Be an ENERGY STAR

Every year, U.S. businesses and organizations spend \$90 billion on energy to run their buildings. Much of that energy is used inefficiently, resulting in unnecessarily high energy bills. Organizations that follow the ENERGY STAR BuildingsSM Integrated Systems Approach are able to reduce the amount of building energy use by 30 percent on average, while increasing the comfort and quality of their facilities.

ENERGY STAR BuildingsSM is a voluntary partnership between U.S. organizations and the U.S. Environmental Protection Agency (EPA) to promote energy efficiency in buildings. Organizations that join the partnership follow a proven, cost-effective strategy to save money by reducing the total energy consumption of their buildings. EPA provides participants in ENERGY STAR BuildingsSM with unbiased technical information, customized support services, public relations assistance and access to a broad range of resources and tools.

EPA's strategy is a five-stage ENERGY STAR BuildingsSM upgrade process that is part of an integrated approach to whole-building energy efficiency. Participants following this approach achieve an internal rate of return of 20 percent or greater on their investment. By planning energy-efficiency upgrades in the order suggested, energy savings from initial upgrades can help pay for more costly upgrades later in the process. This strategy can also ensure that large energy systems, such as HVAC (heating, ventilating and air-conditioning), are the most appropriate size for each facility.

For more information, call the toll-free ENERGY STAR[®] Hotline at 1-888-STAR YES (1-888-782-7937) or visit <http://www.epa.gov/buildings/esbhome/about/background.html>. ■



The ENERGY STAR Buildings 5-Stage Approach

1 Stage 1: GREEN LIGHTS

Installing readily available, proven lighting technologies can reduce lighting energy use by 50 to 70 percent. While saving on energy bills, lighting improvements will also decrease glare and reduce maintenance costs.

2 Stage 2: BUILDING TUNE-UP

These simple, low- or no-cost adjustments to existing building equipment can result in energy savings of 5 to 15 percent, and have a dramatic effect on the scale and type of upgrades needed in later stages.

3 Stage 3: OTHER LOAD REDUCTIONS

Reducing the energy demand of your building by improving the energy efficiency of office equipment and of the building envelope will not only lower electric bills, but also save on heating and cooling costs.

4 Stage 4: FAN SYSTEM UPGRADES

Optimizing the fan systems in your buildings can save 50 to 85 percent in related energy costs, while improving building comfort and reducing unnecessary noise from improperly-sized fan systems.

5 Stage 5: HEATING AND COOLING SYSTEM UPGRADES

Implementing the first four stages of this approach eliminates the heat emitted from inefficient equipment and prevents heating and cooling losses. To further capitalize on these improvements, energy-efficient heating and cooling systems should be "right-sized" to meet the exact needs of your building.

Utility Provider Resources

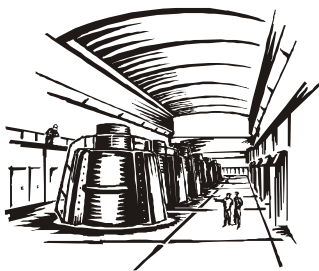

Carolina Power and Light (CP&L) does not offer a rebate or incentive program. However, it does provide energy audits free of charge. CP&L's energy engineering group provides energy analysis for general processes (e.g., boilers, electrotechnology

applications) as well as troubleshooting for specific problems. CP&L can be contacted at 1-800-452-2777.

Duke Power offers a set of programs called Power Partners to help businesses with energy, productivity and environmentally related issues. Incentive programs are available for the purchase of select energy efficient machinery and equipment. Educational programs are also available. Call 1-800-473-4000 for more information on Duke's Power Partners.

Virginia Power offers financial assistance to industrial and commercial customers who install energy efficient electrical equipment. Certain conditions apply for the financial assistance program. Contact an Energy Efficiency Representative at 1-800-275-9387.

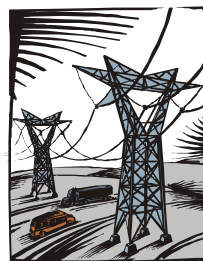

North Carolina Electric Membership Corporation (NCEMC) supplies power for 27 member cooperatives in North and South Carolina and Virginia. NCEMC operates a 24-hour energy operations center and a load management system, and works with engineering and construction management, power supply planning, and Demand Side

Management (DSM) planning. NCEMC provides reliable, affordable and safe electric and related services. Call 919-872-0800 or 1-800-662-8835 for more information. ■

Media News Update

Air Quality News

NEW RULES TO TAKE EFFECT FIGHTING AIR POLLUTION

In October, the North Carolina Environmental Management Commission (EMC) adopted new air pollution rules requiring power plants and other industries to reduce emissions of ozone-forming pollutants by more than two-thirds between 2000 and 2006.

"These rules are a major step forward in carrying out Gov. Hunt's Clean Air Plan for substantially improving air quality, protecting public health and sustaining our economy," said Bill Holman, secretary of the N.C. Department of Environment and Natural Resources. "The rules also allow North Carolina to remain economically competitive with neighboring states if the courts or federal administrative actions strike down stricter federal ozone limits."

Under the new rules, allowable utility emissions would drop from 89,000 tons of nitrogen oxide (NOx) per year in 2000 to 37,294 tons in 2004 (a 58 percent reduction), then to 28,100 tons in 2006 (a 68 percent reduction). Reductions also would be required at other NOx sources including large industrial boilers, electric cogeneration plants, and petroleum pipeline compressor stations.

The EMC also adopted a contingency plan that guarantees a minimum reduction of 56 percent in ozone-causing nitrogen oxide (NOx) emissions from the state's power plants. The contingency

plan would take effect if the courts uphold a legal challenge to a federal order requiring North Carolina and other states to reduce their NOx emissions. Under the contingency rules, electric utilities would have to reduce emissions from 89,000 tons of NOx in 2000 to 39,377 tons in 2004.

North Carolina is not participating in the lawsuit challenging the federal order. The state's utility companies have agreed not to challenge the contingency plan if the current challenge to the federal order is upheld.

Power plants and motor vehicles together account for most of the NOx emissions in North Carolina, and Hunt's Clean Air Plan targets emissions cuts from both. His plan requires the use of low-sulfur gasoline statewide by 2004, enhances and expands the program for inspecting motor vehicle air pollution controls from nine counties to 48 counties in 2006, and provides more incentives for alternative-fuel vehicles that generate less air pollution. Legislators have also approved a record \$56 million for rail and transit projects.

For more information on the new air quality rules, contact Tom Mather at 919-715-7408 or Tom.Mather@ncmail.net or go to daq.state.nc.us/News. ■

IMPROVING EFFICIENCY, *from page 1*

The type and condition of luminaire can also have a dramatic impact on how much of the light generated actually reaches the working surface. For example, in a recent renovation of a series of service station canopies, old-style metal halide fixtures were replaced with a new fixture design. Because of the increased design efficiency in getting the illumination out of the fixture, 20 to 40 percent fewer fixtures were required. The overall result was a brighter, safer, more attractive sales area with a significant reduction in energy.



Removing just one 100-watt light bulb can save over 200 kWh of electricity per year

Optimizing system controls

revolves around the old adage if you don't need it turn it off. Unlike steam, compressed air and HVAC systems, illumination is not normally required unless a space is occupied. Therefore, turning off fixtures in unoccupied spaces can save energy and conceivably reduce maintenance costs. Potential areas of improved control include: conference rooms, offices, storage areas, copy/mail rooms, assembly rooms, break rooms, locker rooms, warehouses, electrical/mechanical rooms, satellite instrumentation houses, boiler rooms, and other frequently unoccupied spaces. Even in exterior applications opportunities exist to optimize controls.

Automating the control of lighting systems can typically be accomplished at a relatively low cost. Photocells, timers, occupancy

sensors and timed switches are all effective devices for providing positive control to existing lighting systems. In new designs, or major renovations, if a building automation system (BAS) exists, then including the lighting to the system can usually be accomplished with minimal additional work. A BAS does not replace the application of other controls, but can provide positive control for extended unoccupied periods, such as evenings and weekends.

When discussing controls, a point frequently brought up regarding increased on/off operation of fixtures is that this would shorten the life of the lamps. But, assuming this is true, the amount of money saved through conservation far outweighs the additional cost that may be incurred from replacing the lamps more often. Also if a space is usually unoccupied, then keeping the fixtures off would actually increase the useful life of the lamps, ballasts and fixtures thereby decreasing maintenance costs.

Thomas D. "Dan" Mull, P.E., C.E.M., is with the Carolina Consulting Group and can be reached at 919-772-0763 or dancgg@ipass.net. To access a summary of energy efficient lighting tips by Energy.com go to energy.com/Resources/Tips_for_Consumers/lighting.asp. ■

Meet DPPEA's Energy Manager



Environmental Engineer John Seymour of the Division of Pollution Prevention and Environmental Assistance (DPPEA) has recently completed NCSU's Energy Management Program. John is available to assist industries in identifying wasteful energy practices and suggesting money saving options. Additionally, DPPEA can conduct industrial waste

assessments with a focus on energy management and efficiency. John can be contacted at 919-715-6503, 800-763-0136 or John.Seymour@ncmail.net.

DPPEA's Industrial Core Sector for Energy Conservation site is located at <http://wrrc.p2pays.org/energy.htm>. Refer to the accompanying list of other energy Web sites for additional resources. ■

<http://aceee.org>

American Council for an Energy-Efficient Economy is dedicated to advancing energy efficiency to promote economic prosperity and environmental protection.

<http://www.aeecenter.org>

The Association of Energy Engineers serves over 8,000 members. Its site includes information on courses, conferences, publications, certification and local chapters.

<http://epa.gov/climatewise/about>

Climate Wise, sponsored by the U.S. EPA, helps business turn energy efficiency and environmental performance into a corporate asset. Climate Wise partners have increased energy efficiency and reduced greenhouse gas emissions while saving money and boosting productivity.

<http://www.ceeformt.org>

Consortium for Energy Efficiency encourages utilities and other partners across the country to voluntarily adopt efficiency programs and specifications.

<http://www.eren.doe.gov>

Energy Efficiency and Renewable Energy Network is an enormous database and search engine on all aspects of energy efficiency, renewable energy and energy efficient technologies.

<http://www.ncsc.ncsu.edu>

The North Carolina Solar Center is a clearinghouse for solar energy programs, research, training and technical assistance for North Carolina citizens. Solar energy is renewable and provides an opportunity for businesses to reduce and gain control over energy costs.

<http://www.oit.doe.gov>

The Office of Industrial Technologies develops and delivers advanced energy efficiency, renewable energy and pollution prevention technologies for application in the U.S. industrial sector.

CALENDAR OF EVENTS

EVENT	DATE	LOCATION	CONTACT
The Strategic Goals Program for Metal Finishers: New Strategies for Success	Dec. 12	Winston-Salem State University, N.C.	Julie Woosley, 800.763.0136
ISO 14001 – An Overview	Dec. 14	NCSU campus, Raleigh, N.C.	Charlie Parrish, 919.515.2358
Developing an EMS Approach to Agriculture and Agribusiness	Dec. 18	McKimmon Center, Raleigh, N.C.	Beth Graves, 800.763.0136
Strategies for Governmental EMS Workshop	Jan. 31	Gastonia, N.C.	Beth Graves, 800.763.0136

Vol. 9, No. 3, Fall 2000

FOCUS: WASTE MINIMIZATION



N.C. DEPARTMENT OF ENVIRONMENT AND NATURAL RESOURCES — DIVISION OF POLLUTION PREVENTION AND ENVIRONMENTAL ASSISTANCE
1639 MAIL SERVICE CENTER
RALEIGH, NC 27699-1639

BULK RATE
U.S. Postage
PAID
Raleigh, NC
Permit No. 1422

Address Service Requested

